

Product Catalogue
10/2023

For aluminium windows

activPilot Topstar ALU

The turn-tilt fitting system for aluminium windows with 16 mm fitting groove

NEW



The processing details regarding burglary-resistant window units can be gathered from the DIN EN 1627 - 1630 system documentation. The lists of fittings in this catalogue are merely intended to give application examples. Get in touch with your Winkhaus contact partner for more details.



Complementary range activPilot Topstar

This catalogue is to provide detailed information on the activPilot Topstar product range.

The activPilot Topstar turn-tilt fitting range is a complement to our extensive activPilot portfolio. You can find the standard activPilot components in our activPilot Concept product catalogue. If you don't have it on hand, request our catalogue. We remain at your disposal for further questions.

New hinge side for activPilot Topstar

What has changed ?

- Increase of the lateral adjustment in the lower hinge area to ± 2.5 mm.
- Increased service life according to DIN 13126-8 H3 to 20,000 switching cycles (when sash hinge rail is used *).
- Increase of the max. permissible sash weight to 150 kg (with use of sash hinge rail *).

* Observe areas of application!

Which components are new?

- Corner hinge EL...IF-N
- Sash hinge FL...IF-N
- Shear S...IF-N
- Turn hinge DL...IF-N



Please note! Fitting parts of the old hinge side must not be mixed with the new-generation fitting parts!

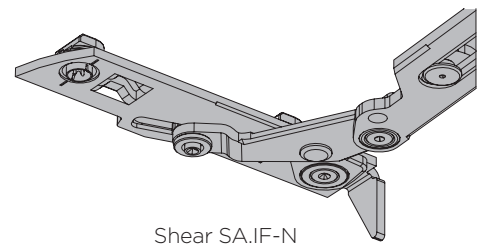

Shear SA.IF-N

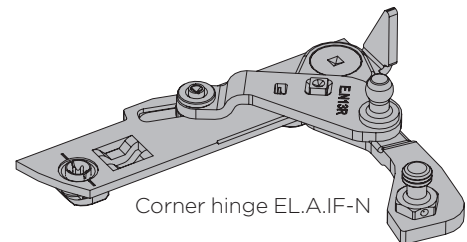

Corner hinge EL.A.IF-N

The following information and illustrations reflect the current state of our development and manufacturing of this product. In order to achieve customer satisfaction and reliability of the hardware components we reserve the right to change the product.

Any information given in this document has been compiled and verified with the greatest care.

Some of the indicated dimensions are rounded measures!

Due to the constant technical progress, changes in legislation and other inevitable changes, we cannot accept any responsibility for the accuracy and completeness of the contents. We are always thankful for suggestions and comments.

Taking into account the information and facts given here with regard to windows (and doors), the fitting system can easily be installed.

Copyright:

© Aug. Winkhaus GmbH & Co. KG, all rights and modifications are reserved.

		Page	
1	General product information	2-23	1
2	Lists of Fittings	24-51	2
3	Drive rods		3
4	Corner drives	52	4
5	Top rods	53-54	5
6	Sash hinges/Corner hinges	55-56	6
7	Shears/Shear hinges	57-58	7
8	Turn hinges/Tilt hinges	59-60	8
9	Extension rods		9
10	Accessories	61-64	10
11	Frame parts	65-67	11
12	Mounting accessories		12
13	Installation Instructions	68-98	13
14	Adjustment/maintenance	99-103	14
15	Installation drawings	104-106	15

1

activPilot Topstar ALU

For aluminium windows with high aesthetic demands.



Technical features

- Easy and quick assembly thanks to profile adjustment
- Suitable for sash weights of up to 130 kg without requiring additional parts for load transfer
- For flush and offset aluminium profiles
- Suitable for narrow frames with small free sizes of the frame
- Easy attachment and removal thanks to bayonet closure

Advantages of the fitting system

- + Easy to combine with the modular activPilot system
- + Compatible with top rails from the activPilot Select product segment
- + Simple three-dimensional adjustment
- + Convenient installation – simply lower the sash on the hinge brackets in a slightly tilted position
- + Energy efficiency – sealing plane is not interrupted
- + Opening angle approx. 90°

activPilot Topstar

As a leading manufacturer of fully-concealed fitting solutions Winkhaus is always keen to develop its products consistently and to adapt them to the changing requirements of the customers. The result of this process is activPilot Topstar.

activPilot Topstar unites the advantages of energy efficiency and load capacity of large and heavy windows which are required to offer superior design without visible hinges. activPilot Topstar seamlessly integrates with the existing fully-concealed fitting solutions activPilot Elegance and activPilot Select adding further solution possibilities in the field of design windows.

Thanks to the activPilot Topstar's movement kinematics directed inwardly, it is possible to manufacture flush windows with narrow shadow joints from 4 mm. In offset profiles it is possible to achieve a free size of the frame from 4 mm to the wall reveal.

For the production of activPilot Topstar fittings we use high-tensile steel in order to enable the sashes weighing up to 130 kg to be securely operated in spite of the compact design. In addition, highly-hardened stainless steel keeps help to reduce wear and tear on sensitive friction surfaces improving the endurance of hinge components.

When developing the activPilot Topstar fitting system we attached much importance not only to the technical features, but also to the assembly friendliness and the easy accessibility of the adjustment screws. When the sash is lowered in the tilt position onto the corner hinge, the bearing points are located as if by themselves. This prevents the hinges from being subjected to adverse loads from the outset.

Modular design

activPilot optimises window construction. For the window builder, less components and multifunctionality mean uncomplicated and fast processing and rational mounting. Pre-mounted components and the unique design additionally ensure that additional functions and safety classes can be achieved easily by retrofitting. activPilot thus sets the scene for sustainably cutting your production, warehousing, logistics and administration costs.

The locking system with octagonal locking bolts

activPilot enhances comfort. The functionally perfect locking mechanism not only guarantees precise entry of the locking bolt into the frame keep, but also a perfect seal. This is ensured by the increased air gap tolerance and the new octagonal locking bolt which allows easy adjustment of the contact pressure. Even adjusting forces and the non-positive and positive system fit of the components give this fitting the required stability and long-term functionality.

Add-on functions

activPilot gives you the ability to react flexibly to customer requests. Innovative multi-purpose components make it easy to retrofit features at any time. The use of a duo and/or tri functional element makes it simple to add a fail safe device with integrated limiter support and balcony door catch. The variable tilt device supports different sash tilt angles and thus fast, easily adjustable ventilation settings.

Design

activPilot offers you and your customers real added value. Surprising details, discreet accents, ergonomic design and comprehensive functions characterise the overall concept of the fitting system. In short its attractive design will be a crucial factor when it comes to your customers making a purchase decision. activPilot also offers other convincing arguments such as outstanding durability, easy-to-clean surfaces, intuitive operation and, last but not least, aesthetically pleasing windows.

Surface

activPilot fittings feature a surface refinement finish based on nanotechnology, which is applied in our in-house plating shop. This surface stands out due to its very high resistance to all environmental influences. This is verified by quality controls consisting of alternate climate and salt spray testing according to DIN EN ISO 9227 and is certified by tests on a regular basis. Winkhaus also carries out tests in outside areas, thus testing component behaviour under realistic conditions. This enables Winkhaus to offer a ten-year warranty for functions and surfaces.

Effective security

Thanks to this unique modular system, any window can be modified to achieve the required security standard - easily, quickly and cost-efficiently. There is no need for custom parts. Depending on the number and type of keeps, various security levels are achievable using the same platform.

At our works, comprehensive and strict tests - along with ongoing functional monitoring - ensure maximum security for customers. Approval marks and certificates by independent test authorities confirm our results. You can therefore rely on activPilot meeting customer requirements for a secure fitting system. Locking bolts are made of high-strength steel; even standard types guarantee effective basic security. Depending on the number and type of keeps, the fitting system can be enhanced for compliance with stricter security classes - including burglar protection to DIN V ENV 1627-1630, RC2.

Quality standard

The Winkhaus group successfully passed a group certification of production sites according to DIN EN ISO 9001:2015 / DIN EN ISO 50001:2011.

The group certification ensures that we use the same criteria and procedures in all Winkhaus subsidiaries and thus we can always offer consistent quality for our customers.



Winkhaus has successfully passed the demanding QM 328 certification.

activPilot fittings from Winkhaus are certified in accordance with QM 328. The turn-only and turn-tilt fittings for windows and patio doors undergo a large number of tests in this stringent certification programme, which verifies aspects such as durability and quality control mechanisms. The certificate stands as a testament to Winkhaus' long tradition in high quality products.

Endurance test

Winkhaus activPilot is certified in accordance with EN 13126-8 (endurance test for turn-only and turn-tilt fittings) and EN 1191 (endurance test for windows and doors). The fitting thus complies with EN standards. Winkhaus' own permanent control in accordance with established production control guidelines as well as regular external monitoring by ift Rosenheim ensure outstanding product quality guaranteed on a long-term basis.

Your partner for service

Our services are solution-orientated, reliable and precisely geared to match your requirements - just as you would expect from your partner. We are at your disposal whenever you need us. With application engineers on site, professional help from our product data service and innovative software solutions to help optimise your workflows, we ensure you are able to work as you require and also broaden your professional service capabilities. What's more, our comprehensive product information system and sophisticated logistics guarantee fast delivery any time you need it.

Proper screw fixing in terms of load of security-relevant fitting components

In order to ensure the endurance and operating safety of windows and balcony doors over their expected service life, major importance must be attached to the installation of security-relevant fitting components!

Manufacturers of windows and balcony doors are responsible for fixing the fitting elements on the sash and the frame in a professional way and they must make sure that the specifications are adhered to.

Important: Follow these guidelines! Always use screws that are long enough to bear the loads.

Basic technical features of the activPilot fitting system

In the following section you will find the general features that apply to all activPilot fitting components in the sash area, unless otherwise described on the corresponding product pages.

- Face plate width of sash fitting parts: 16 mm
- Overlapping system linkage without connecting plates
- Delivery state of sash fitting parts: centre fixed in turn position
- Safety locking pin as an adjustable octagonal bolt
- Sash fitting parts can be used right/left, unless otherwise stated.

Zertifikat / Certificate



Zertifikatsnr. / Certificate No.: 228-7019950-1-17

Dreh- und Drehkippsbeschläge für Fenster und Fenstertüren Turn and tilt-turn hardware for windows and casement doors

Produkt
product
activPilot, proPilot

max. Flügelgewicht
max. casement weight
max 200 kg

Einsatzbereich
field of application
Systeme mit entsprechender Beschlagaufnahme
Systems with suitable hardware groove

Hersteller
manufacturer
Aug. Winkhaus GmbH & Co. KG
August-Winkhaus-Str. 31, D 48291 Telgte

Produktionsstandort
production site
Aug. Winkhaus GmbH & Co. KG
August-Winkhaus-Str. 31, D 48291 Telgte



Mit diesem Zertifikat wird bescheinigt, dass das benannte Bauprodukt den Anforderungen des zugrundeliegenden ift-Zertifizierungsprogramms in der aktuellen Fassung entspricht.

- Erstellung von Produktfamilien des aufgeführten Bauproduktes und Erstprüfung durch eine akkreditierte Prüfstelle nach EN 13126-8:2017 unter Berücksichtigung der Anwendungsdiagramme
- Einführung und Aufrechterhaltung einer werkseigenen Produktionskontrolle durch den Hersteller
- Erstinspektion des Werkes und der werkseigenen Produktionskontrolle durch ift-Q-Zert
- kontinuierliche Fremdüberwachung des Werkes und der werkseigenen Produktionskontrolle durch ift-Q-Zert

Dieses Zertifikat wurde erstmals am 18. November 2008 ausgestellt und gilt 5 Jahre, wenn sich zwischenzeitlich die Festlegungen in der oben angeführten technischen Spezifikation oder die Herstellbedingungen im Werk oder in der werkseigenen Produktionskontrolle selbst nicht wesentlich verändert haben.

Das Zertifikat darf nur unverändert vervielfältigt werden. Alle Änderungen der Voraussetzungen für die Zertifizierung sind dem ift-Q-Zert mit den erforderlichen Nachweisen unverzüglich schriftlich anzuzeigen.

Das Unternehmen ist berechtigt, das benannte Bauprodukt gemäß der ift-Zeichensatzung mit dem „ift-zertifiziert“-Zeichen zu kennzeichnen.

Dieses Zertifikat enthält 2 Anlage/n.

This certificate attests that the building product mentioned fulfils the requirements of the underlying ift-certification scheme in its current version.

- compilation of product families of the building product listed and initial type-testing by an accredited testing body as per EN 13126:8:2017 based on the application diagrams
- implementation and maintenance of a factory production control by the manufacturer
- initial inspection of the production site and the factory production control by ift-Q-Zert
- continuous third-party control of the production site and the factory production control by ift-Q-Zert

This certificate was first issued on 18. November 2008 and will remain valid for 5 years, as long as neither the conditions laid down in the technical specification listed above nor the manufacturing conditions in the production site nor the factory production control itself are modified significantly.

The reproduction of the certificate without any change from the original is permitted. Any changes to the prerequisites applicable to certification shall be immediately communicated in writing to ift-Q-Zert accompanied by the necessary evidence.

The company is authorized to affix the "ift-certified"-mark to the building product mentioned according to the ift-rules for use of the "ift-certified"-mark.

This certificate contains 2 annexes.

Grundlage(n) / Basis:

ift-Zertifizierungsprogramm für Beschläge
ift-certification scheme for hardware (QM 328)
Ausgabe/Issue 2018

EN 1191
EN 12400
bis Klasse 3
up to class 3



Dauerfunktion
resistance to repeated opening and closing

EN ISO 9227
EN 1670
bis Klasse 5
up to class 5



Korrosionsschutz
corrosion protection

Christian Kehrer

ift Rosenheim
25. März 2019

Christian Kehrer
Leiter der ift-Zertifizierungs- und Überwachungsstelle
Head of ift Certification and Surveillance



Ulrich Sieberath

Prof. Ulrich Sieberath
Institutsleiter
Director of Institute

228 7019950

10. Oktober 2023

Gültig bis / Valid until:



www.ift-rosenheim.de

2018-01/1797

ift Rosenheim GmbH
Theodor-Gietl-Str. 7-9
D-83026 Rosenheim

Kontakt
Tel.: +49 8031 261-0
Fax: +49 8031 261-290
www.ift-rosenheim.de

Prüfung und Kalibrierung – EN ISO/IEC 17025
Inspektion – EN ISO/IEC 17020
Zertifizierung Produkte – EN ISO/IEC 17065
Zertifizierung Managementsysteme – EN ISO/IEC 17021

Notified Body 0757
POZ-Stelle: BAY 18



You will find further certificates and updates at www.winkhaus.com

Anlage I annex 1 Seite I page 1 von I of 3
 Hersteller I manufacturer: Aug. Winkhaus GmbH & Co. KG
 Ausgabedatum I date of issue: 25. März 2019



Zertifikatsnr. I Certificate No.: 228-7019950-1-17

In der Zertifizierung enthaltene Produktfamilien für Fenster- und Fenstertürsysteme mit geeigneter Beschlagaufnahme.

Product families for window and casement door systems with groove designed for accommodation of hardware, covered by certification.

Ifd. Nr./ no.	Ausführung Bandseite/ type hinge side	Ausführung Flügelbeschlag/ type casement hardware	Beschreibung der Ausführung der blendrahmenseligen Beschlagausführung detail description of frame member hardware type				Klassifizierung nach EN 13126-8:2017 classification as per EN 13126-8:2017			
			Winkelband/ top stay connecting part	Scherenlager/ stay arm support	Eckband/ corner hinge	Ecklager/ corner pivot	1	2	3	4
							Dauerfunktionsfähigkeit/ durability	Masse (in kg)/ mass	Korrosionsbeständigkeit/ corrosion resistance	Prüfgrößen (in mm)/ test sizes
1	activPilot K 100	activPilot K 100	SK2.20-13	SL.KS.3-6	FL.K 20-6-20	EL.K 6-3-16	H2	100	5	1300 mm x 1200 mm
2	activPilot K 100	activPilot K 100	SK2.20-13	SL.KS.3-6	FL.K 20-6-20	EL.K 6-3-16	H2	100	5	900 mm x 2300 mm
3	activPilot K 130 S	activPilot K 130 S	SK2.20-13	SL.K.3-6.130	FL.K 20-6-28.130	ESV 6-3-16	H3	100	5	1300 mm x 1200 mm
4	activPilot Comfort PADK 100	activPilot Comfort PADK 100	SK2.PA.20-13	SL.KS.3-6	FLE.FWPA 20-13	ESV 6-3-16	H2	100	5	1300 mm x 1200 mm
5	activPilot Comfort PADK 100	activPilot Comfort PADK 100	SK2.PA.20-13	SL.KS.3-6	FLE.FWPA 20-13	ESV 6-3-16	H2	100	5	900 mm x 2300 mm
6	activPilot Comfort PADM 100	activPilot Comfort PADM 100	SK2.PAD. 20-13	SL.KS.3-6	FLE.FPAD 20-13	ESV 6-3-16	H2	100	5	1300 mm x 1200 mm
7	activPilot Comfort PADM 100	activPilot Comfort PADM 100	SK2.PAD. 20-13	SL.KS.3-6	FLE.FPAD 20-13	ESV 6-3-16	H2	100	5	900 mm x 2300 mm
8	activPilot C 130	activPilot C 130	SC2.20-13	SL.C.3-6	FL.C-W. 20-13	EL.CS. 6-3-22	H3	130	5	1400 mm x 1550 mm
9	activPilot K 130	activPilot K 130	SK2.20-13	SL.KB.3-6	FWV 20-13	ESVW 6-3-16	H2	130	5	1300 mm x 1200 mm

Anlage I annex 1 Seite I page 2 von I of 3
 Hersteller I manufacturer: Aug. Winkhaus GmbH & Co. KG
 Ausgabedatum I date of issue: 25. März 2019



Zertifikatsnr. I Certificate No.: 228-7019950-1-17

10	activPilot K 130	activPilot K 130	SK2.20-13	SL.KB.3-6	FWV 20-13	ESVW 6-3-16	H2	130	5	900 mm x 2300 mm
11	activPilot ALU 130	activPilot ALU 130	SK2.20-13	SL.KB.3-6	FWV 20-13	ESVW 6-3-16	H2	130	5	1300 mm x 1200 mm
12	activPilot ALU 130	activPilot ALU 130	SK2.20-13	SL.KB.3-6	FWV 20-13	ESVW 6-3-16	H2	130	5	900 mm x 2300 mm
13	activPilot K 130 S	activPilot K 130 S	SK2.20-13	SL.K.3-6.130	FL.K 20-6-28.130	ESV 6-3-16	H2	130	5	1300 mm x 1200 mm
14	activPilot K 130 S	activPilot K 130 S	SK2.20-13	SL.K.3-6.130	FL.K 20-6-28.130	ESV 6-3-16	H2	130	5	900 mm x 2300 mm
15	activPilot H 130	activPilot H 130	SH2.T. 18-13-12	SL.HT.18-12	FL.HT. 18-13-12	EL.HT.Z. 18-12	H3	130	5	1300 mm x 1200 mm
16	activPilot H 150	activPilot H 150	SH2.T. 18-13-12	SL.HT.18-12	FL.HT. 18-13-12	EL.HT.Z. 18-12	H3	150	5	900 mm x 2300 mm
17	activPilot Giant	activPilot Giant	SXL.20-13	SL.XL	FL.XL	EL.XL	H3	200	5	1550 mm x 1400 mm
18	activPilot Giant	activPilot Giant	SXL.20-13	SL.XL	FL.XL	EL.XL	H2	200	5	900 mm x 2300 mm
19	activPilot Select K 100	activPilot Select K 100	SK.SE	ohne without	FL.SE	EL.K.SE	H2	100	5	1300 mm x 1200 mm
20	activPilot Select H 130	activPilot Select H 130	SH.SE. 20-9.Z.	ohne without	FL.SE	EL.H.SE. 20-9.Z. mit/with FLS.SE	H2	130	5	1300 mm x 1200 mm
21	activPilot Topstar	activPilot Topstar	SH.IF.24-13	ohne without	FL.IF	EL.H.IF. 24-13	H2	130	5	1300 mm x 1200 mm

Anlage / annex 1
 Hersteller / manufacturer:
 Ausgabedatum / date of issue:

Seite / page 3 von / of 3
 Aug. Winkhaus GmbH & Co. KG
 25. März 2019



Zertifikatsnr. / Certificate No.: 228-7019950-1-17

22	activPilot Topstar	activPilot Topstar	SH,IF.24-13	ohne without	FL,IF	EL,H,IF.24-13	H2	130	5	900 mm x 2300 mm
23	activPilot Select K 150	activPilot Select K 150	SK,SE	ohne without	FL,SE	EL,K,SE mit/with FLS,SE	H2	150	5	1550 mm x 1400 mm
24	activPilot Select K 150	activPilot Select K 150	SK,SE	ohne without	FL,SE	EL,K,SE mit/with FLS,SE	H2	150	5	900 mm x 2300 mm
25	activPilot Select ALU 150	activPilot Select ALU 150	SK,SE	ohne without	FL,SE	EL,K,SE mit/with FLS,SE	H2	150	5	1550 mm x 1400 mm
26	activPilot Select H 150	activPilot Select H 150	SH,SE.29-13	ohne without	FL,SE	EL,H,SE.29-13 mit/with FLS,SE	H2	150	5	1550 mm x 1400 mm
27	proPilot	proPilot	SK,U.2.20-13	SL,K,U.3-3	FL,K,U.6	EL,K,U.3-3	H2	70	4	1300 mm x 1200 mm
28	proPilot	proPilot	SK,U.2.20-13	SL,K,U.3-3	FL,K,U.6.100	EL,K,U.3-3	H2	100	4	1300 mm x 1200 mm
29	activPilot C 150	activPilot C 150	SC2.20-13	SL,C.3-6	FL,C-W.20-13	EL,CS.6-3-22	H3	150	5	900 mm x 2300 mm
30	activPilot C 150	activPilot C 150	SC2.20-13	SL,C.3-6	FL,C.20-6-28	EL,C.6-3-22	H3	150	5	900 mm x 2300 mm
31	activPilot C 130	activPilot C 130	SC2.20-13	SL,C.3-6	FL,C.20-6-28	EL,C.6-3-22	H3	130	5	1400 mm 1550 mm

Die Ergebnisse sind auf folgende Ausführungsvarianten übertragbar: Beschlagsausführung links/rechts, alle zulässigen Größen gemäß Anwendungsdiagramm sowie andere Falz- und Profilgeometrien. Die technische Dokumentation des Beschlagherstellers, insbesondere die entsprechenden Anwendungsdiagramme, ist zu beachten.
 The results can be applied to the following design variants: hardware type left/right, all permissible sizes in accordance with the application diagram as well as other rebate and profile geometries. Observe technical documents of hardware manufacturer, in particular the relevant diagrams.

1

Obligations to provide information and instructions

This document brings together important information and details regarding different fittings and their further processing. The information is particularly intended for window and balcony door manufacturers and fitting and structural component retailers. Accidents and physical damage can be avoided if you observe the information contained in this information. For this reason, you must always ensure that you pass on the relevant documents when you hand fittings over to somebody else. Information and documents should be handed over in printed format, on a CD ROM or online, for example.

Guidelines for the use of locking systems and fittings

Gütegemeinschaft Schlösser und Beschläge e.V., Velbert issues guidelines offering assistance for the use of locking systems and fittings for windows, doors and patio doors. These guidelines are established in cooperation with the trade association of the locks and fittings industry in Velbert as well as the testing institute PIV which is also based in Velbert. If required, they are agreed with the VFF technical committee and ift Rosenheim. As a result the experience and test findings of several decades are considered.

The guidelines provide information about the intended use and maintenance of fittings for windows and patio doors. It is mandatory to observe these guidelines.

The current guidelines can be accessed in different languages at the following Internet address:
<http://www.beschlagindustrie.de/ggsb/richtlinien.asp>



As an alternative to using the www address, you can also scan the QR Code with your smartphone!

Follow this link to find the applicable and binding guidelines on the following topics:

- VHBH - Fittings for windows and patio doors [with guidelines / instructions on the product and liability]
- VHBE - Fittings for windows and patio doors [with guidelines / instructions for end users]
- TBDK - Attachment of supporting fitting components of turn and turn-tilt fittings [with definitions of turn and turn-tilt fittings as well as their possible mounting positions]
- FPKF - Safety and cleaning shears for tilt sashes and tilting fanlights [use of safety and cleaning shears]
- FPDF - Sash limiters for variable turn position of sashes [sash limiters controlled by central locking system – definitions and tests]



The VHBH guideline among others contains the chapter “Obligation to give instructions”. A schematic illustration shows the documents and information to be submitted to the different target groups for respecting the instructions obligation. The building owner must pass on the documents defined in the chapter “Obligation to give instructions” to the end user.



Gütegemeinschaft Schlösser und Beschläge e.V.
 Richtlinie: TBDK
ORIGINALFRESSUNG
 Ausgabe: 2016-05-05

Richtlinie
Befestigung tragender Beschlagteile von Dreh- und Drehkipp-Beschlägen mit Definitionen zu Dreh- und Drehkipp-Beschlägen sowie deren möglichen Einbautagen

Inhalt

1	Verrent	3
2	Anwendungsbereich	3
3	Begriffe	6
4	Dezertifizierungsfähigkeit – Grenzen der Richtlinie	7
5	Empfehlungen für die Befestigung	8
6	Durchführung der Prüfungen	8
7	Vorgaben zu den Kriterien	15
8	Literaturhinweis	22

Herausgeber:
 Gütegemeinschaft Schlösser und Beschläge e.V.
 Offerstraße 12
 42551 Velbert
 Phone: +49 (0)2051 / 95 06 - 0
 Fax: +49 (0)2051 / 95 06 - 20
 www: www.beschlagindustrie.de
www.beschlagindustrie.de/ggsb/richtlinien.asp

Hinweis
 Technische Angaben und Empfehlungen dieser Richtlinie beruhen auf dem Kenntnisstand bei Drucklegung. Es gilt der Inhalt des „Disclaimer“ auf der o.g. Internet-Seite.

Richtlinie | BUK
1 / 23

Product liability guidelines

Turn and turn-tilt fittings for windows and patio doors

According to the current product liability legislation dealing with a manufacturer's liability for his products (§ 4 ProdHaftG) please observe the following information on turn and turn-tilt fittings for window and patio door sashes. The manufacturer will not accept any liability for noncompliance with these specifications.

1. Product information and intended use

Turn and turn-tilt fittings within the meaning of this definition are single handle turn-tilt fittings for windows and patio doors as used in building applications. They are used to move window sashes into a turn position or a tilt position limited by the shear version using a hand lever. Turn and turn-tilt fittings are used on vertically installed windows and patio doors made of wood, PVC-U, aluminium or steel and their corresponding material combinations. Conventional turn and turn-tilt fittings within the meaning of this definition close window and patio door sashes and move them to different ventilation positions. As a rule, the counterforce of a seal must be overcome when closing. Other uses are not in accordance with the intended use. Burglary-resistant windows and patio doors, window and patio doors for wet rooms and those for use in environments with aggressive, corrosion-promoting air contents require fittings with performance characteristics coordinated and agreed separately for the respective application. Open window and window door sashes only achieve a shielding function and do not fulfil any requirements for joint tightness, impact rain tightness, sound insulation, heat protection and burglary resistance. In windy conditions and draughts, window and window sashes must be closed and locked. Wind and draught in the sense of this definition are present if the window or patio door sashes in one of the opening positions open or close automatically and uncontrollably due to air pressure or air suction. Fixed open positions of window and patio door sashes can only be achieved with arresting additional fittings. The resistance to wind loads in closed and locked state depends on the respective construction of the relevant window and patio doors. If wind loads must be transferred in accordance with DIN EN 12210 (particularly test pressure p_3), suitable fitting combinations must be agreed in conjunction with the respective window construction and the frame material and agreed separately. In general, the turn and turn-tilt fittings can meet the requirements for barrier-free apartments in accordance with DIN 18025. However, this requires corresponding fitting combinations and assemblies in the windows and patio doors, which must be coordinated and agreed separately.

2. Misuse

Misuse – i.e. the use of a product in a manner contrary to the manufacturer's instructions – of turn-tilt fittings for windows and patio doors occurs

- if obstacles are placed in the opening area preventing the intended use.
- if sashes of windows / patio doors are pushed or hit against the window reveal, either contrary to the manufacturer's instructions or in an uncontrolled way (e.g. by wind), that the fittings, the frame materials or other individual parts of the window sash or the patio door sash are damaged or destructed or subsequent damage occurs
- if additional loads act on the sashes of windows or patio doors (e.g. children swinging on them).
- if someone grasps in the gap between the frame and sash when closing the window (risk of injury).

3. Liability

All fittings must be selected from the original Winkhaus activPilot fitting component range. Winkhaus accepts no liability if non-original or unauthorised system accessory parts are used.

Important: The screw / clamping connection of load-bearing fitting components, such as corner, shear and sash hinges must be designed according to the TBDK guidelines. Please adapt the fixing procedure of the fitting components to the load situation.

4. Product performance – Manufacturer's instructions for use

The maximum sash weights for the individual fitting versions may not be exceeded. The component with the lowest permissible loading capacity determines the maximum weight of the sash. Please observe the diagrams and component installation instructions.

4.1 Sash sizes and areas of application

The graphs in the application diagrams show the permitted sash rebate height to width ratios, as determined by different weights of glass and/or overall glass thickness. The resulting sash rebate dimensions or sash formats (portrait/ landscape) as well as the maximum sash weight may under no circumstances be exceeded.

4.2 Application diagram for determination of the permissible sash sizes

The application diagrams for this fitting series for the determination of permissible sash sizes are described and explained separately on the following pages.

4.3 Composition of fittings

You must comply with the manufacturer's specifications regarding the configuration of fittings (e.g. the use of additional shears, the layout of fittings for burglary-resistant windows and patio door sashes, etc.).

5. Product maintenance

Security-relevant fitting parts are to be inspected at least once a year to check for wear and to ensure they are firmly secured in position. Fastening screws must be tightened and faulty components must be replaced as required. In addition, maintenance/cleaning work must be carried out at least once a year.

All mobile parts and locking points of fittings should be greased and tested for function.

Only oils and greases not affecting the materials of the fitting may be used.

The only cleaning and maintenance materials to be used are those which will not adversely affect the corrosion-resistant properties of the fitting components.



Adjustment work to the fittings – particularly in the area of the corner drive and the shears – as well as the replacement of parts and mounting and removal of opening sashes must be carried out by a trained specialist.

5.1 Maintaining surface quality

- The fittings and rebate spaces must be adequately ventilated, particularly during the construction stage, so that they are not exposed to the direct effects of moisture or condensation. It must be ensured in any case by appropriate measures that there is no possibility for (permanently) humid room air to condense in the rebate area.
- The fittings must be kept free from deposits and soiling due to building materials (building dust, gypsum plaster, cement etc). Possible soiling from plaster, mortar etc. must be removed prior to bonding with water.
- Corrosive vapours (e.g. formic acid, acetic acid, ammonia, amine and ammonia compounds, aldehydes, phenols, chlorine, tannic acid etc.) combined with even a small amount of condensation can cause rapid corrosion of the fittings. Therefore, such evaporation in the area of the windows must be avoided at all costs.

- Furthermore no sealants that cure with acetic or other acids, or sealants containing any of the above-mentioned substances, must be used. Both direct contact with the sealant and vapours released from it can damage the surface.
- Only use a mild and pH neutral detergent in diluted form to clean the fittings. Under no circumstances use aggressive acidic cleaners or scouring agents containing the substances listed above.

6. Obligations to provide information and instructions

For the implementation of information and instruction obligations as well as for the maintenance work the following documents are available. They must be submitted to (intermediate) dealers and manufacturers and to the end customer.

Planning documentation

Product catalogues

Installation Instructions

Maintenance and care instructions as well as operating instructions















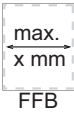
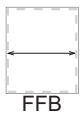
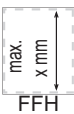
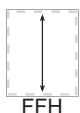

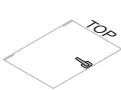
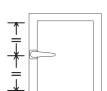



7. Use of type-related fittings

The variants for the individual fitting systems (e.g. tilt and top-hung sash fittings or parallel action fittings providing an additional ventilation position by means of a circumferential gap all around the sash) are to be handled accordingly with regard to product information and intended use, misuse, product performance, product maintenance, information and instruction obligations depending on the applicable characteristics.

8. Storage

Before the fitting components are assembled, they must be stored on a dry, protected and level surface.

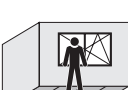
Declaration of symbols

	Max. Sash weight: x kg		Basic set of fittings
	Max. Sash size: x m ²		Optional fittings
	Max. Sash rebate width (FFB): x mm		Size-dependent fittings depending on sash rebate width (FFB)
	Max. Sash rebate height (FFH): x mm		Size-dependent fittings depending on sash rebate height (FFH)
	Constant handle height		"TOP" marks the upper edge of the window.
	Central handle height		Pot hinge version
	Turn sash (D)		Rebate hinge version
	Turn-tilt sash (DK)		Item for use on PVC-U windows
	Turn/Turn-tilt double sash (D/DK-Stulp)		Item for use on wooden windows with 12 mm airgap
	Design of centre turn sash (D) (3-sash units)		Item for use in wooden windows with 4 mm airgap and 15 mm overlap
	Parallel action		Item for use in wooden windows with 4 mm airgap and 18 mm overlap
	Interior view		Item for use on aluminium windows
	Exterior view		

1

Packing key in the Winkhaus logistics system

The shipping units are configured in a way to enable you easy handling of our products in your works from small boxes to bulky pallets. For instance, we provide KLTs (small load carriers) in different sizes which are eco-friendly and facilitate logistics. The reusable packaging units, which can be stacked on a europallet, have a bar code and enable optimal stock organisation and easy transport to the relevant workstations.

The packaging used for the products in question can be found on the corresponding product pages.

BL  BL Goods packed in PE bags with bar code

KT  KT Goods packed in cardboard boxes with bar code

BD  BD Tied goods with barcode

K3  K3 Small cardboard box with bar code. Dim: 395 x 295 x 205 mm

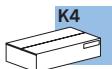
K4  K4 Big cardboard box with bar code. Dim: 595 x 395 x 205 mm

KK  KK Small KLT (small load carrier) 4321. Dim: 400 x 300 x 214 mm with cover, bar code, sealed, stackable

GK  GK Big KLT (small load carrier) 6412. Dim: 600 x 400 x 214 mm with cover, bar code, sealed, stackable

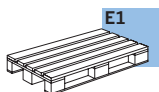
E1  E1 europallet with KLT Pallet size 800 x 1,200 mm

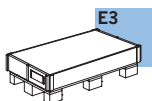
E3  E3 One-way pallet with cover box and bar code

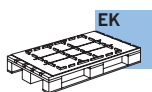
EK  EK Europallet with KLT and fixing plate (avoids shifting of goods) Pallet size 800 x 1,200 mm

EA  EA Europallet with frame and bar code Pallet size 800 x 1,200 mm

EWK  EWK Disposable cardboard box E3, L6 or L7

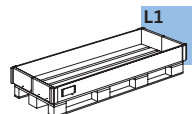
L1  L1 Reusable pallet I for long goods with frame and bar code Pallet size 800 x 1,800 mm

L2  L2 Reusable pallet II for long goods with frame and bar code Pallet size 800 x 2,400 mm

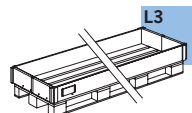
L3  L3 Reusable pallet III for long goods with frame and bar code Pallet size 800 x 3,500 mm

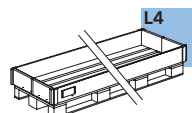
L4  L4 Reusable pallet IV for long goods with frame and bar code Pallet size 800 x 4,200 mm

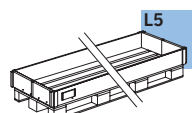
L5  L5 Reusable pallet V for long goods with frame and bar code Pallet size 800 x 6,500 mm

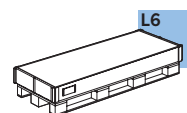
L6  L6 One-way pallet with cover box for long goods with bar code Pallet size 800 x 1,800 mm

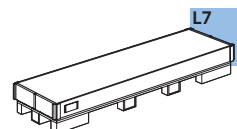
L7  L7 One-way pallet with cover box for long goods with bar code Pallet size 800 x 2,400 mm

Glossary

1

Code

AB.G.D	Drilling protection	GAVM	Locking drive rod activPilot, central handle position
ADS	Cover strip	GG	Handle set
ADP	Adapter	GK	Constant handle position
AKR	Automatic shootbolt	GRT.RB	Round arch set
AL...	Support plate		
ANS	Mounting element	HC	Timber windows, rebate version
AP.HH	Fitting punch, lever	HFG	Window Handle Case HFG
AP...SE	Adapter plate, activPilot Select	HT	Timber windows, pot hinge version
AS.DSL	Mini ventilation unit (turn position)		
AS.SBA	Mini vent keep		
ASP ER-A	End plate		
ASS AR	Connecting rail	IF	activPilot Topstar
AWDR	Stroke limiter		
BK	Balcony door catch	K.EL	Corner hinge cap
BK.KR	Catch bolt	K.FL	Sash hinge cover
BO	Catch bolt	K.SB	Shear hinge cap, timber
BS	Threshold	K.SK	Shear hinge insert cap
BST AP/FS	Fittings punch	K.SL	Shear hinge cover
		KB	Tilt hinge
		KBG	Tilt limiter
D	Backset	KE	Coupling element
DB	Turn limiter	KLB	Tilt hinge insert
DBG	Turn limiter	KR	Shootbolt
DFE	Dual function element	KUE-T1	Cable transition, separable
DL	Turn hinge insert		
DL...ET	Turn hinge, 1 piece	LE.B	Drill jig
DLW ERW	Turn hinge bracket	LE.FR	Milling jig
DML	Turn middle hinge	LE.N	Jig
DS	Window lock	LIN AP/FS	Ruler of fittings press
		LM-RG	Round handle
E	Corner drive	M	Interlocking rod
E1.A	Corner drive for studio windows	MK	Interlocking rod, extendable
E1.MSL	Corner drive with variable tilt device	MS.SO	Interlocking rod, double sash, keep top
E1.SBS	Corner drive for double-sash window		
EL	Corner hinges	MS.SU	Interlocking rod, double sash, keep bottom
ELK	Corner hinge cap	MSL.OS	Variable tilt device top rod
FBP	Window limiter	NML	Groove centre position
FH ...	Sash lifter		
FL	Sash hinges	OBV	Opening limiter
FL...PADS	Sash hinge, PADS	OS	Top rod
FL...PAD/ PADM	Sash hinge PAD/PADM	OS...PA...	Top rod, PADK
FL...PADK	Sash hinge, PADK	OS. ...E	Top rod (turn before tilt)
FLK	Sash hinge cover	OS.A	Screw clip
FLS.SE	Sash hinge rail, activPilot Select		
FSA	Fail safe device FSA	PA	Parallel action
FSF	Fail safe device FSF	PAD	Parallel action, turn
FSR	Rebate shear	PADK	Parallel action, turn-tilt
FT	Spacer		
GAK	Drive rod, constant handle position	RA.DB.SE	Frame connection turn limiter
GAKA	Drive rod, constant handle position, lockable	RT.DFE-TFE	Frame part, dual/triple function element
GAM	Drive rod, central handle position	RT.DFE-TFE.S	Frame part, dual/triple function element, double-sash windows
GAMA	Drive rod, central handle position, lockable		
GASK	Double sash drive rod, constant handle position	RT.MSL	Frame part, variable tilt device
GASM	Double sash drive rod, central handle position		

Item description

S.FL	Sash hinge plug	...LS	Fitting direction left
SA	Shootbolt keeps	...RS	Fitting direction right
SA.IF	Shear activPilot Topstar aluminium	...AGR	anthracite grey (similar to RAL 7016)
SB SZV	Keep, claw bolt	...BR	brown (similar to RAL 8019)
SBA...	Keep, contact pressure	...BZ-AM	bronze - antique brass
SBA...T	Mini vent keep	...BZ-CU	bronze - coppery
SBK	Security tilt keep	...BZ-RB	bronze - red brown
SBK...E	Tilt keep (tilt before turn)	...CW	cream white (similar to RAL 9001)
SBK...PA	Tilt keep (with slider), PADK	...EV1	anodised silver
SBK...SP	Security tilt keep with gap locking device	...F1	silver coloured
SBS...	Security keep	...F1-elox	(similar to F1) anodised silver
SBS...PA	Security keep, PADK	...F3	gold coloured
SBS...PAB	Security keep PAB, PADK	...F3-MG	gold mat
SBS...PAD	Security keep PAD	...F9	titanium coloured
SC	Shear, rebate hinge	...LBR	clay brown
SC...A	Shear studio window	...PW	pearl white (similar to RAL 1013)
SC...E	Shear (tilt before turn)	...SG	silver-grey (similar to RAL 7001)
SC...PA...	Shear, PADK	...SGB	grey (similar to RAL 9006)
SC...PAD...	Shear PAD	...SGR	grey (similar to RAL 7037)
SCO	Shear, without turn restriction	...SL	silver look (zinc galvanised)
SE	activPilot Select	...SW	jet black
SH...T	Shear, pot hinge	...WS	white (similar to RAL 9016)
SH.IF	Shear activPilot Topstar Timber		
SK.IF	Shear activPilot Topstar PVC-U		
SL	Shear hinge		
SL.HC	Shear hinge, timber rebate hinge		
SLK	Shear hinge cap, rebate hinge		
SNH	Faceplate fastener		
SP R	Faceplate		
SR	Control unit SR		
SZP	Geared cover plate		
TFE	Triple function element		
UEB	Overlap		
UF	Packer		
V	Distance between locking points		
VBST	Connection piece		
V.AK	Extension rod		
VK.AK	Extension rod, extendable		
VS R	Connection rod		
VS RB	Connection rod round-arch window		
XL	Components from activPilot Giant range		
ZSR	Additional shear		
ZSRE	Additional shear (tilt before turn)		
ZSS	Anti-slam device		
ZV...	Claw bolt		
ZV.RT	Claw bolt, frame part		

Guidelines for using application diagrams

• Prerequisites:

- When fixing load-bearing components, please consider the TBDK guidelines. The tractive forces shown in the table have to be achieved. The suitable proof must be provided by the window manufacturer.
- The values given here apply to the shear hinge. An extra test of the corner hinge is not necessary in case the fixing situation is identical to that of the shear hinge.

m [kg]	F [N]
50	1400
60	1650
70	1900
80	2200
90	2450
100	2710
110	3000
120	3250
130	3525
140	3900
150	4200

• Please control:

- Are window dimensions within the range highlighted in grey?
- Is the intersection point to be determined located to the left of the limiting curve of the glass weight?

m [kg] = max. sash weight in kg
 F [N] = tractive force on the shear hinge in N

• Example:

Intended window dimensions:

- FFB = 1.100 mm
- FFH = 1.800 mm
- GG = 40 kg/m² (corresponds to the cyan curve)

The intersection point "S" is located in the area highlighted in grey and to the left of the limiting curve of the filling weight (GG = 40 kg/m²), i. e. in the permitted area.

• General notes:

On the establishment of application diagrams, the following values were considered:

- Glass weight GG ~ 2.5 kg/m² per mm of glass thickness
- Profile weight ~ 3.25 kg/RM

Please find more detailed information on the website <http://www.ift-service.de/awd/ift/start.faces> as well as on <http://www.fvsb.de/ggsb/richtlinien.asp>.



1

activPilot Topstar

Application diagram for ascertaining the admissible sash sizes

Max. sash weight 130 kg

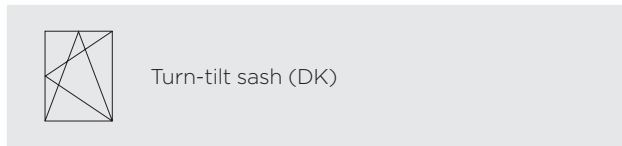
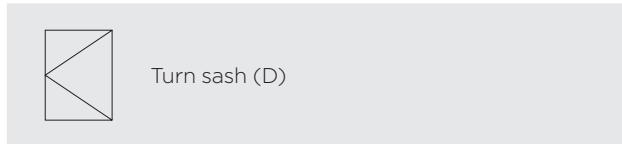
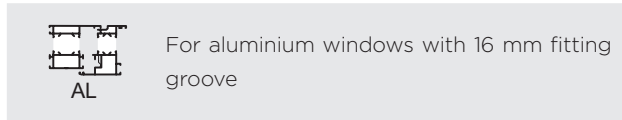

Width-to-height ratio and additional load

Value calculated without additional load for a width-to-height ratio of 2:1.

The application graphs have been calculated without additional loads. Please consult your authorised contact person for further information on how to calculate the maximum permissible window sash format with an additional load.

Advice for use

The application range permitted for using Winkhaus fitting is highlighted in grey in the application graphs. However, it is essential not to use the entire grey-highlighted section, but only those parts which are on the left-hand side of the curve for the respective GG filling weight.

Application range

All fittings must be selected from the original Winkhaus activPilot fitting component range. Winkhaus accepts no liability if non-original or unauthorised system accessory parts are used.

- Min. sash rebate width 380 mm
- Max. sash rebate width 1725 mm
- From 1475 mm sash rebate width with additional shear ZSR
- Min. sash rebate height 230 mm
- Max. sash rebate height 2800 mm
- Max. sash size 3 m²
- Ratio between sash rebate width: sash rebate height ≤ 2:1
- Airgap top and bottom in horizontal position 12 +1 mm

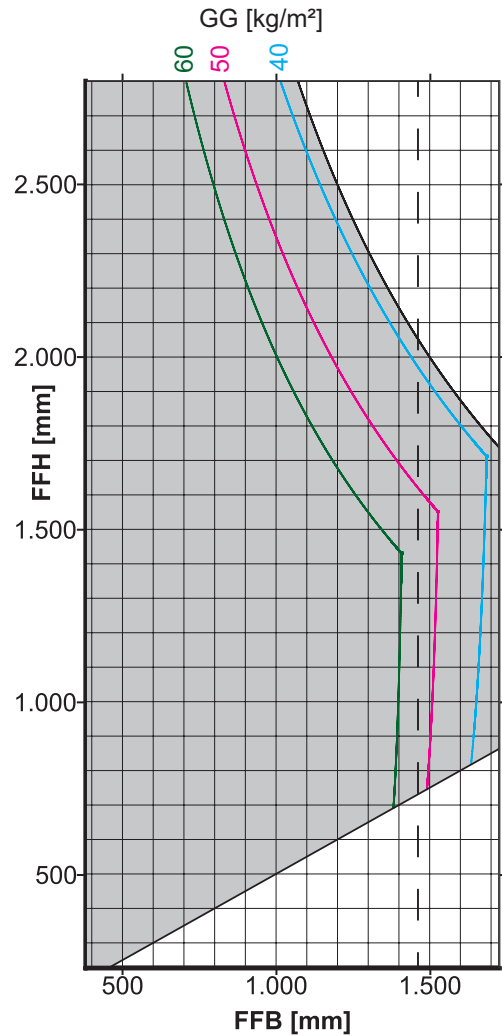

AWD_01.50_NR30_DK_130 kg_ohne_Zusatzlast_2_m

Abbreviations

- FFB = Sash rebate width [mm]
- FFH = Sash rebate height [mm]
- GG = Glass weight per square metre [kg/m²]
- ZSR = Additional shear (section on right of interrupted line)

Observe instructions on window profile

You must specifically take into account information provided by the profile manufacturer or system owner when determining the maximum sash sizes and sash weights!



Important: The screw / clamping connection of load-bearing fitting components, such as corner, shear and sash hinges must be designed according to the TBDK guidelines. Please adapt the fixing procedure of the fitting components to the load situation.









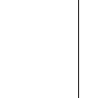

Overview of min. dimensions for drive rods D = 15.5 mm

The following overview shows the applications supported by top corner drives. Use depends on the variant "tilt & turn" or "turn double sash", and the window size. Depending on the application, other elements can be used as alternatives to top corner drives.

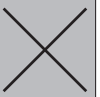

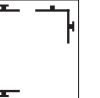
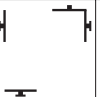

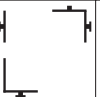



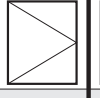

If the sash rebate height is smaller than 750 mm, the airgap in the shear area must be 12 mm at least.

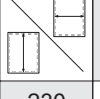
Turn-tilt type, constant, single sash



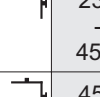

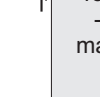

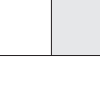

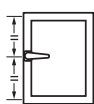

				
	380 - 480	481 - 550	551 - max	
230 - 325				
326 - 420				
421 - max				

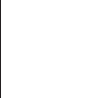
Turn/Turn-tilt double sash type, constant

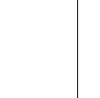
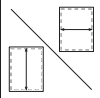
					
	481 - max	280 - 480	480 - 550	551 - max	
230 - 450					230 - 450
451 - 545					451 - max
546 - max					

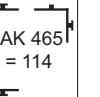

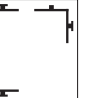

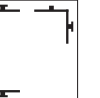





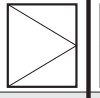

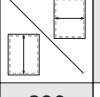

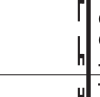
Turn-tilt type, central, single sash

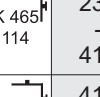

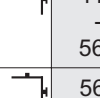
				
	380 - 480	481 - 550	551 - max	
230 - 325				
326 - 510				
511 - max				

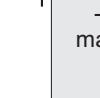
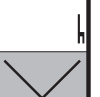
Turn/Turn-tilt double sash type, central

					
	481 - max	280 - 480	480 - 550	551 - max	
230 - 410					230 - 410
411 - 560					411 - 560
561 - 710					561 - max
711 - 980					
981 - max					

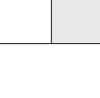
1













Overview of min. dimensions for drive rods D = 7.5 mm

The following overview shows the applications supported by top corner drives. Use depends on the variant "tilt & turn" or "turn double sash", and the window size. Depending on the application, other elements can be used as alternatives to top corner drives.

















If the sash rebate height is smaller than 750 mm, the airgap in the shear area must be 12 mm at least.

Turn-tilt type, constant, single sash















				
		380 - 480	481 - 550	551 - max
338 - 433				
434 - 530				
531 - max				

Turn/Turn-tilt double sash type, constant

					
	481 - max	280 - 480	480 - 550	551 - max	
338 - 433					338 - 433
434 - 530					434 - 530
531 - max					531 - max























Turn-tilt type, central, single sash



			
		380 - 480	481 - 550
381 - 574			
575 - 710			
711 - max			

Turn/Turn-tilt double sash type, central



					
	481 - max	280 - 480	480 - 550	551 - max	
381 - 410					381 - 410
411 - 574					411 - 574
575 - 710					575 - max
711 - 980	GASM 1050				
981 - max					

Overview of max. dimensions for drive rods D = 15.5 and 7.5 mm

This overview shows how the gear side is designed when tall windows up to 2,725/2,800 mm are involved. The maximum sash height depends on the position of the window handle, central or constant.

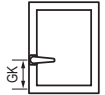



Turn-tilt type, constant, single sash



		min - max*
2226 - 2475	MK.250-1 + GAK.2225-...	
2476 - 2725	MK.500-1 + GAK.2225-...	



Turn/Turn-tilt double sash type, constant



			
	min - max*	min - max*	
2226 - 2475	MS.SO.250-1 + GASK.2225-...	MK.250-1 + GAK.2225-...	2226 - 2475
2476 - 2725	MS.SO.500-1 + GASK.2225-...	MK.500-1 + GAK.2225-...	2476 - 2725

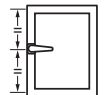



Turn-tilt type, central, single sash



		min - max*
2301 - 2800	MK.250-1 + GAM.2300-3 + MK.250-1	

Turn/Turn-tilt double sash type, central



			
	min - max*	min - max*	
2301 - 2800	MS.SO.250-1 + GASM.2300-3 + MS.SU.250-1	MK.250-1 + GAM.2300-3 + MK.250-1	2301 - 2800

* Please observe the "Diagrams to determine permissible sash sizes"!

Explanation of fitting lists

The fitting lists consist of two pages each. The first page shows the fitting composition as a graphic illustration whereas the second page includes a possible fitting configuration in the shape of a tabular list.

2



The processing details regarding burglary-resistant window units can be gathered from the DIN EN 1627 - 1630 system documentation. The lists of fittings in this catalogue are merely intended to give application examples. Please get in touch with your Winkhaus contact partner.

Our register system allows you to quickly allocate the listed component to the item in the fitting overview drawing.

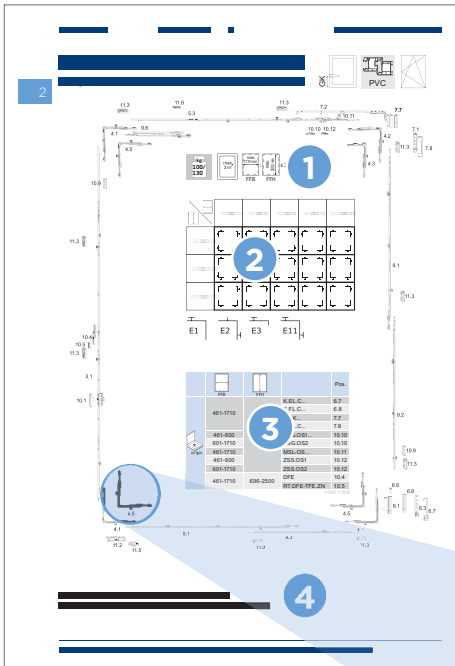

Pos.	Part No.	Part Name	Pos.	Part No.	Part Name
1	401-000	AL SL 10x15	10.1	AL SL	10x15
401-001	421-000	GAK 400	3.1		
401-002	401-000	GAK 700	3.1		
401-003	501-000	GAK 300-1	3.1		
401-004	501-000	GAK 100-1	3.1		
401-005	1000-000	GAK 1000-2	3.1		
401-006	1000-000	GAK 1000-1	3.1		
401-007	1000-000	GAK 1000-2	3.1		
401-008	1000-000	GAK 1000-1	3.1		
401-009	1000-000	GAK 1000-2	3.1		
401-010	1000-000	GAK 1000-1	3.1		
401-011	1000-000	GAK 1000-2	3.1		
401-012	1000-000	GAK 1000-1	3.1		
401-013	1000-000	GAK 1000-2	3.1		
401-014	1000-000	GAK 1000-1	3.1		
401-015	1000-000	GAK 1000-2	3.1		
401-016	1000-000	GAK 1000-1	3.1		
401-017	1000-000	GAK 1000-2	3.1		
401-018	1000-000	GAK 1000-1	3.1		
401-019	1000-000	GAK 1000-2	3.1		
401-020	1000-000	GAK 1000-1	3.1		
401-021	1000-000	GAK 1000-2	3.1		
401-022	1000-000	GAK 1000-1	3.1		
401-023	1000-000	GAK 1000-2	3.1		
401-024	1000-000	GAK 1000-1	3.1		
401-025	1000-000	GAK 1000-2	3.1		
401-026	1000-000	GAK 1000-1	3.1		
401-027	1000-000	GAK 1000-2	3.1		
401-028	1000-000	GAK 1000-1	3.1		
401-029	1000-000	GAK 1000-2	3.1		
401-030	1000-000	GAK 1000-1	3.1		
401-031	1000-000	GAK 1000-2	3.1		
401-032	1000-000	GAK 1000-1	3.1		
401-033	1000-000	GAK 1000-2	3.1		
401-034	1000-000	GAK 1000-1	3.1		
401-035	1000-000	GAK 1000-2	3.1		
401-036	1000-000	GAK 1000-1	3.1		
401-037	1000-000	GAK 1000-2	3.1		
401-038	1000-000	GAK 1000-1	3.1		
401-039	1000-000	GAK 1000-2	3.1		
401-040	1000-000	GAK 1000-1	3.1		
401-041	1000-000	GAK 1000-2	3.1		
401-042	1000-000	GAK 1000-1	3.1		
401-043	1000-000	GAK 1000-2	3.1		
401-044	1000-000	GAK 1000-1	3.1		
401-045	1000-000	GAK 1000-2	3.1		
401-046	1000-000	GAK 1000-1	3.1		
401-047	1000-000	GAK 1000-2	3.1		
401-048	1000-000	GAK 1000-1	3.1		
401-049	1000-000	GAK 1000-2	3.1		
401-050	1000-000	GAK 1000-1	3.1		
401-051	1000-000	GAK 1000-2	3.1		
401-052	1000-000	GAK 1000-1	3.1		
401-053	1000-000	GAK 1000-2	3.1		
401-054	1000-000	GAK 1000-1	3.1		
401-055	1000-000	GAK 1000-2	3.1		
401-056	1000-000	GAK 1000-1	3.1		
401-057	1000-000	GAK 1000-2	3.1		
401-058	1000-000	GAK 1000-1	3.1		
401-059	1000-000	GAK 1000-2	3.1		
401-060	1000-000	GAK 1000-1	3.1		
401-061	1000-000	GAK 1000-2	3.1		
401-062	1000-000	GAK 1000-1	3.1		
401-063	1000-000	GAK 1000-2	3.1		
401-064	1000-000	GAK 1000-1	3.1		
401-065	1000-000	GAK 1000-2	3.1		
401-066	1000-000	GAK 1000-1	3.1		
401-067	1000-000	GAK 1000-2	3.1		
401-068	1000-000	GAK 1000-1	3.1		
401-069	1000-000	GAK 1000-2	3.1		
401-070	1000-000	GAK 1000-1	3.1		
401-071	1000-000	GAK 1000-2	3.1		
401-072	1000-000	GAK 1000-1	3.1		
401-073	1000-000	GAK 1000-2	3.1		
401-074	1000-000	GAK 1000-1	3.1		
401-075	1000-000	GAK 1000-2	3.1		
401-076	1000-000	GAK 1000-1	3.1		
401-077	1000-000	GAK 1000-2	3.1		
401-078	1000-000	GAK 1000-1	3.1		
401-079	1000-000	GAK 1000-2	3.1		
401-080	1000-000	GAK 1000-1	3.1		
401-081	1000-000	GAK 1000-2	3.1		
401-082	1000-000	GAK 1000-1	3.1		
401-083	1000-000	GAK 1000-2	3.1		
401-084	1000-000	GAK 1000-1	3.1		
401-085	1000-000	GAK 1000-2	3.1		
401-086	1000-000	GAK 1000-1	3.1		
401-087	1000-000	GAK 1000-2	3.1		
401-088	1000-000	GAK 1000-1	3.1		
401-089	1000-000	GAK 1000-2	3.1		
401-090	1000-000	GAK 1000-1	3.1		
401-091	1000-000	GAK 1000-2	3.1		
401-092	1000-000	GAK 1000-1	3.1		
401-093	1000-000	GAK 1000-2	3.1		
401-094	1000-000	GAK 1000-1	3.1		
401-095	1000-000	GAK 1000-2	3.1		
401-096	1000-000	GAK 1000-1	3.1		
401-097	1000-000	GAK 1000-2	3.1		
401-098	1000-000	GAK 1000-1	3.1		
401-099	1000-000	GAK 1000-2	3.1		
401-100	1000-000	GAK 1000-1	3.1		

- 1** Maximum application ranges
- 2** Overview min./max. dimensions
- 3** Optional components
- 4** Applied distance between locking points

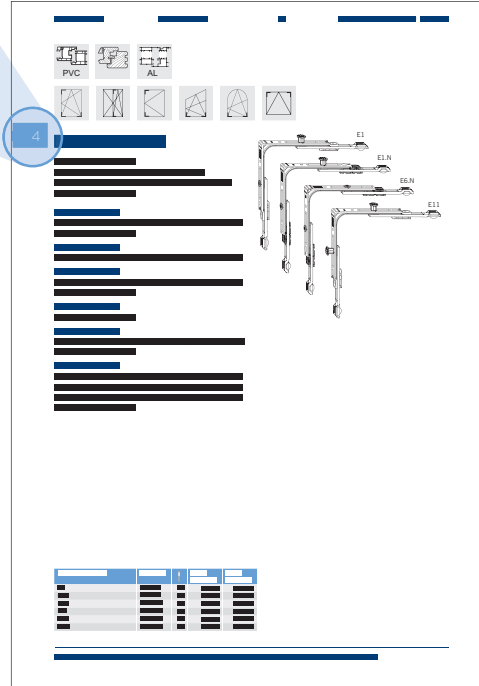
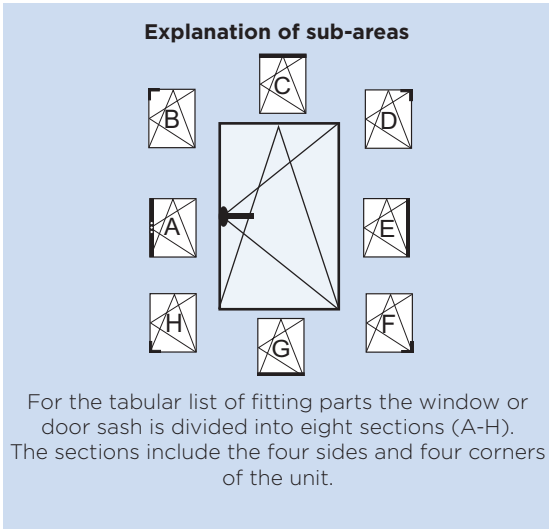

The window or door unit is divided into 8 sections (4 corners, 4 sides). In order to determine a complete fitting set of a certain sash size, it is necessary to ascertain items from all the sections (1). In each subarea (1), the articles to be used (4) and their item numbers (5) can be read, depending on the application area FFB (2) and FFH (3). The frame part types (6) are also supplemented with their position number (7) and quantity (8). The item numbers (5/7) refer to the position of the component within the fitting overview (page 1).

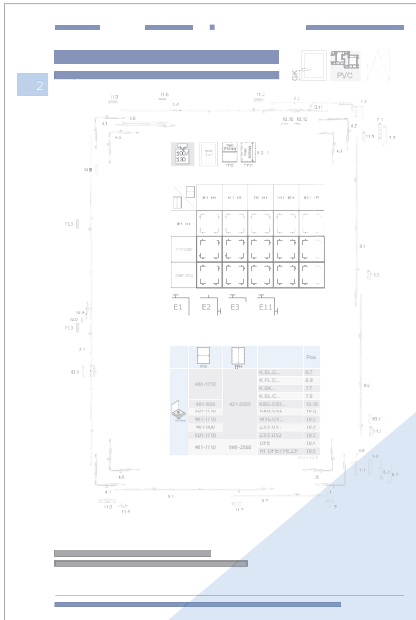

1	2	3	4	5	5	5	6	7	8
	FFB	FFH		Pos.		Pos.			
9	461-1710	421-2500	AB.G.D.15,5	10.1	AL D...	10.9			
	461-920	421-460	GAK.465	3.1					
	461-1160	461-580	GAK.710	3.1					
	461-1390	581-695	GAK.830-1	3.1			SBS.K...	11.3	1x
	461-1700	696-850	GAK.945-1	3.1			SBS.K...	11.3	1x
		851-1075	GAK.1100-1	3.1			SBS.K...	11.3	1x
		1076-1325	GAK.1325-2	3.1			SBS.K...	11.3	2x
		1326-1525	GAK.1550-2	3.1			SBS.K...	11.3	3x
		1526-1775	GAK.1775-2	3.1			SBS.K...	11.3	2x
	461-1710	1776-2000	GAK.2000-2	3.1			SBS.K...	11.3	2x
		2001-2225	GAK.2225-2	3.1			SBS.K...	11.3	2x
		2226-2475	GAK.2225-2	3.1	MK.250-1	9.1	SBS.K...	11.3	3x
		2476-2500	GAK.2225-2	3.1	MK.500-1	9.1	SBS.K...	11.3	3x
	461-1160	421-580	E11	4.5			SBS.K...	11.3	2x
	461-1710	581-2500	E1	4.1			SBS.K...	11.3	1x

- 1 Section (A-H)
- 2 Sash rebate width (FFB) (application ranges on items level)
- 3 Sash rebate height (FFH) (application ranges on items level)
- 4 Items to be used
- 5 Position number of items
- 6 Type of frame part
- 7 Position number of frame parts
- 8 Number of frame parts
- 9 i marks a line with items that are always used, regardless of size





Lists of profiles

In order to ensure easy and secure installation, all hinge parts have a profile adjustment.

The attribution of individual items to various profiles is depicted in the following table.

Aliplast **NML 9 mm**
UEB 17 mm

Blyweert

EL 		SK 		DL 		RA 	
EL.A.IF-N.75.LS	5102990	SA.IF-N.75.LS	5103006	DL.A.IF-N.75.LS	5103018	RA.DB.A.IF.75.LS	5077801
EL.A.IF-N.75.RS	5102989	SA.IF-N.75.RS	5103005	DL.A.IF-N.75.RS	5103017	RA.DB.A.IF.75.RS	5077800
		SA.IF-N.E.75.LS	5103012				
		SA.IF-N.E.75.RS	5103011				





Aliplast **NML 9 mm**
UEB 18 mm

Ecofutural, Imperial, Superial, Genesis, Star65, Star75, Star 90

EL 		SK 		DL 		RA 	
EL.A.IF-N.75.LS	5102990	SA.IF-N.75.LS	5103006	DL.A.IF-N.75.LS	5103018	RA.DB.A.IF.75.LS	5077801
EL.A.IF-N.75.RS	5102989	SA.IF-N.75.RS	5103005	DL.A.IF-N.75.RS	5103017	RA.DB.A.IF.75.RS	5077800
		SA.IF-N.E.75.LS	5103012				
		SA.IF-N.E.75.RS	5103011				



AluK **NML 9 mm**
UEB 18 mm

Venta, Triton

EL 		SK 		DL 		RA 	
EL.A.IF-N.75.LS	5102990	SA.IF-N.75.LS	5103006	DL.A.IF-N.75.LS	5103018	RA.DB.A.IF.75.LS	5077801
EL.A.IF-N.75.RS	5102989	SA.IF-N.75.RS	5103005	DL.A.IF-N.75.RS	5103017	RA.DB.A.IF.75.RS	5077800
		SA.IF-N.E.75.LS	5103012				
		SA.IF-N.E.75.RS	5103011				





Alumil **NML 9 mm**
UEB 18 mm

11000, 11500, 11600, 20000, 20650, S77

EL 		SK 		DL 		RA 	
EL.A.IF-N.74.LS	5102988	SA.IF-N.74.LS	5103004	DL.A.IF-N.74.LS	5103016	RA.DB.A.IF.74.LS	5077799
EL.A.IF-N.74.RS	5102987	SA.IF-N.74.RS	5102996	DL.A.IF-N.74.RS	5103015	RA.DB.A.IF.74.RS	5077798

Heroal **NML 9 mm**
UEB 20 mm

W 72

EL 		SK 		DL 		RA 	
EL.A.IF-N.78.LS	5102992	SA.IF-N.78.LS	5103008	DL.A.IF-N.78.LS	5103020	RA.DB.A.IF.78.LS	5078731
EL.A.IF-N.78.RS	5102991	SA.IF-N.78.RS	5103007	DL.A.IF-N.78.RS	5103019	RA.DB.A.IF.78.RS	5078730



Reynaers **NML 9 mm**
UEB 20 mm

CS77 (9NML)

EL 		SK 		DL 		RA 	
EL.A.IF-N.75.LS	5102990	SA.IF-N.75.LS	5103006	DL.A.IF-N.75.LS	5103018	RA.DB.A.IF.75.LS	5077801
EL.A.IF-N.75.RS	5102989	SA.IF-N.75.RS	5103005	DL.A.IF-N.75.RS	5103017	RA.DB.A.IF.75.RS	5077800
		SA.IF-N.E.75.LS	5103012				
		SA.IF-N.E.75.RS	5103011				

Sapa **NML 13 mm**
UEB 18 mm

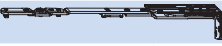
Avantis 70

EL 		SK 		DL 		RA 	
EL.A.IF-N.87.LS	5102994	SA.IF-N.87.LS	5103010	DL.A.IF-N.87.LS	5103022	RA.DB.A.IF.74.LS	5077799
EL.A.IF-N.87.RS	5102993	SA.IF-N.87.RS	5103009	DL.A.IF-N.87.RS	5103021	RA.DB.A.IF.74.RS	5077798
		SA.IF-N.E.87.LS	5103014				
		SA.IF-N.E.87.RS	5103013				

Lists of Fittings

Turn fitting system – constant handle position Basic equipment	26
Turn-tilt fitting system – central handle position Basic equipment	28
Turn-tilt fitting system – constant handle position Suitable for burglary-resistant windows RC2 / RC2 N	30
Turn-tilt fitting system – central handle position Suitable for burglary-resistant windows RC2 / RC2 N	32
Turn double sash fitting system – constant handle position Basic equipment with circumferential locking points	34
Turn double sash fitting system – central handle position Basic equipment with circumferential locking points	36
Turn double sash fitting system – constant handle position Basic equipment with claw bolt	38
Turn double sash fitting system – central handle position Basic equipment with claw bolt	40
Turn double sash fitting system – constant handle position Suitable for burglary-resistant windows RC2 / RC2 N	42
Turn double sash fitting system – central handle position Suitable for burglary-resistant windows RC2 / RC2 N	44
Turn-tilt fitting system – constant handle position Basic equipment – Tilt before turn	46
Turn-tilt fitting system – central handle position Basic equipment – Tilt before turn	48
Tilt fanlight Basic equipment	50

Turn-tilt fitting – constant handle position

Basic equipment

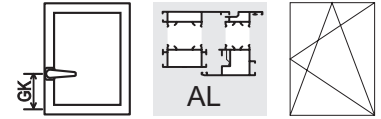

2

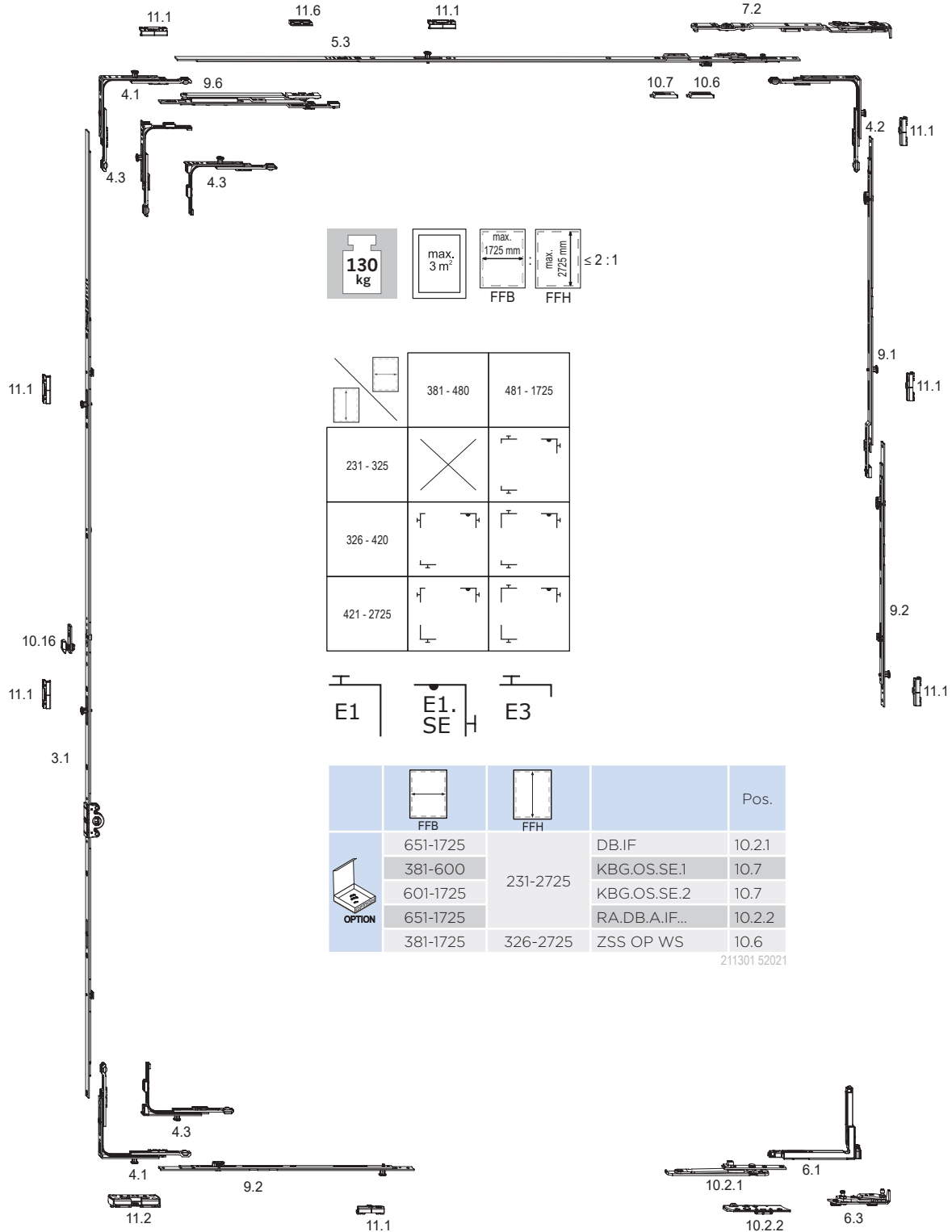







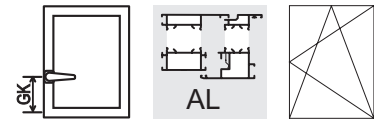



The locking distances must be agreed with the system provider.

Turn-tilt fitting – constant handle position

Basic equipment



				Pos.		Pos.		Pos.		Pos.		
	481-650	231-325	GAK.465	3.1			GK = 114					
	381-840	326-420	GAK.465	3.1			GK = 114					
	381-920	421-460	GAK.465	3.1			GK = 210					
	381-1400	461-700	GAK.710	3.1			GK = 210					
	381-1700	701-850	GAK.945	3.1	FSF	10.16	GK = 260					
	381-1725	851-1100	GAK.1100-1	3.1	FSF	10.16	GK = 375		SBA.A...	11.1	1x	
		1101-1325	GAK.1325-1	3.1	FSF	10.16	GK = 550		SBA.A...	11.1	1x	
		1326-1550	GAK.1550-1	3.1	FSF	10.16	GK = 550		SBA.A...	11.1	1x	
		1551-1775	GAK.1775-2	3.1	FSF	10.16	GK = 550		SBA.A...	11.1	2x	
		1776-2000	GAK.2000-2	3.1	FSF	10.16	GK = 1050		SBA.A...	11.1	2x	
		2001-2225	GAK.2225-2	3.1	FSF	10.16	GK = 1050		SBA.A...	11.1	2x	
2226-2475	GAK.2225-2	3.1	FSF	10.16	GK = 1050		SBA.A...	11.1	3x			
	MK.250-1	9.1										
2476-2725	GAK.2225-2	3.1	FSF	10.16	GK = 1050		SBA.A...	11.1	3x			
		MK.500-1	9.1									
	381-480	326-2725	E3	4.3					SBA.A...	11.1	1x	
	481-650	231-325	E3	4.3					SBA.A...	11.1	1x	
	481-1725	326-2725	E1	4.1					SBA.A...	11.1	1x	
	381-550	326-2725	OS.SE.550	5.3								
	481-550	231-325	OS.SE.550	5.3								
	551-800	231-2725	OS.SE.800	5.3								
	801-1025		OS.SE.1025-1	5.3					SBA.A...	11.1	1x	
	1026-1250		OS.SE.1250-1	5.3					SBA.A...	11.1	1x	
	1251-1475		OS.SE.1250-1	5.3	MK.250-0	9.1				SBA.A...	11.1	1x
	1476-1500		OS.SE.1025-1	5.3	MK.250-1	9.1	ZSR SL	9.6	FT WSK... SBA.A...	11.6 11.1	1x 2x	
1501-1725	461-2725	OS.SE.1250-1	5.3	MK.250-1	9.1	ZSR SL	9.6	FT WSK... SBA.A...	11.6 11.1	1x 3x		
	381-1725	326-2725	E1.SE	4.2	SA.IF-N...	7.2			SBA.A...	11.1	1x	
	481-650	231-325	E1.SE	4.2	SA.IF-N...	7.2			SBA.A...	11.1	1x	
	381-1725	1061-1485	M.500-1	9.2					SBA.A...	11.1	1x	
		1486-1735	M.750-1	9.2					SBA.A...	11.1	1x	
		1736-2235	MK.750-1	9.1	M.500-1	9.2			SBA.A...	11.1	2x	
		2236-2485	MK.750-1	9.1	M.750-1	9.2			SBA.A...	11.1	2x	
		2486-2725	MK.750-1	9.1	MK.750-1	9.1	M.500-1	9.2	SBA.A...	11.1	3x	
	481-650	231-325	FL.IF-N...	6.1	EL.A.IF-N...	6.3						
	381-1725	326-2725	FL.IF-N...	6.1	EL.A.IF-N...	6.3						
	1041-1450	231-2725	M.500-1	9.2					SBA.A...	11.1	1x	
	1451-1725		M.750-1	9.2					SBA.A...	11.1	1x	
	381-840	326-420	E3	4.3					SBK.A...	11.2	1x	
	381-1725	421-2725	E1	4.1					SBK.A...	11.2	1x	
	481-650	231-325	E3	4.3					SBK.A...	11.2	1x	

Turn-tilt fitting – central handle position

Basic equipment

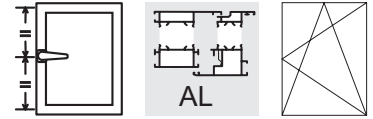

2

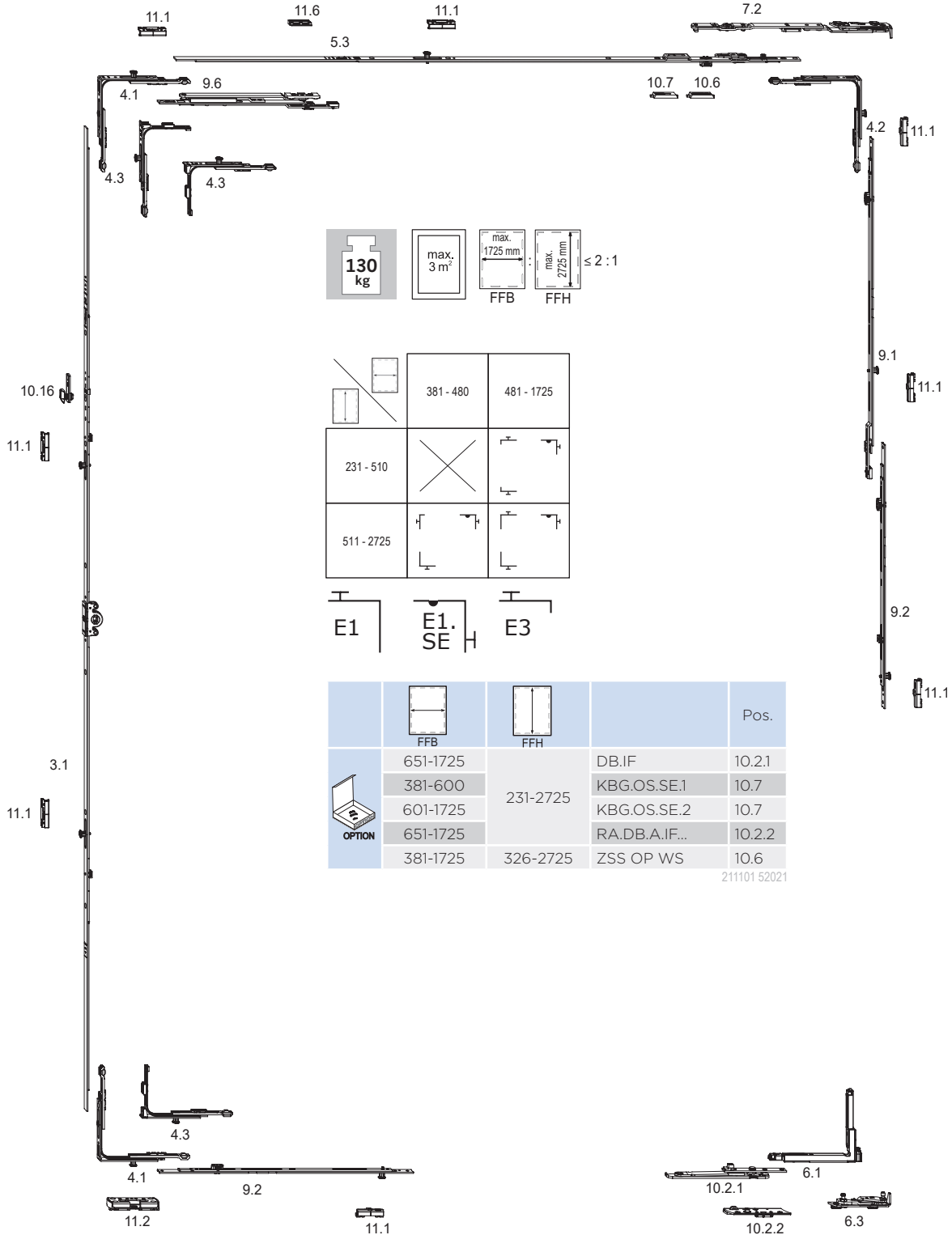

$\leq 2 : 1$

	381 - 480	481 - 1725
	231 - 510	
	511 - 2725	



				Pos.
	651-1725		DB.IF	10.2.1
	381-600	231-2725	KBG.OS.SE.1	10.7
	601-1725		KBG.OS.SE.2	10.7
	651-1725		RA.DB.A.IF...	10.2.2
	381-1725	326-2725	ZSS OP WS	10.6



211101 52021

The locking distances must be agreed with the system provider.

Turn-tilt fitting – central handle position

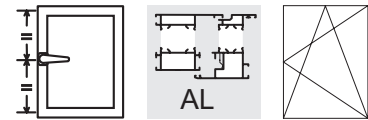
Basic equipment



				Pos.		Pos.		Pos.		Pos.		
	481-650	231-325	GAK.465	3.1			GK = 114					
	481-1020	326-510	GAM.800	3.1								
	381-1420	511-710	GAM.800	3.1								
	381-1725	711-980		GAM.1050	3.1	FSF	10.16					
		981-1400		GAM.1400-1	3.1	FSF	10.16			SBA.A...	11.1	1x
		1401-1800		GAM.1800-2	3.1	FSF	10.16			SBA.A...	11.1	2x
1801-2300			GAM.2300-3	3.1	FSF	10.16			SBA.A...	11.1	3x	
	2301-2725		GAM.2300-3 MK.250-1	3.1 9.1	FSF	10.16	MK.250-1	9.1	SBA.A...	11.1	5x	
	381-480	511-2725	E3	4.3					SBA.A...	11.1	1x	
	481-1020	231-510	E3	4.3					SBA.A...	11.1	1x	
	481-1725	511-2725	E1	4.1					SBA.A...	11.1	1x	
	381-550	511-2725	OS.SE.550	5.3								
	481-550	231-510	OS.SE.550	5.3								
	551-800		OS.SE.800	5.3								
	801-1025	231-2725	OS.SE.1025-1	5.3					SBA.A...	11.1	1x	
	1026-1250		OS.SE.1250-1	5.3					SBA.A...	11.1	1x	
	1251-1475		OS.SE.1250-1	5.3	MK.250-0	9.1			SBA.A...	11.1	1x	
	1476-1500		OS.SE.1025-1	5.3	MK.250-1	9.1	ZSR SL	9.6	FT WSK... SBA.A...	11.6 11.1	1x 2x	
1501-1725	OS.SE.1250-1		5.3	MK.250-1	9.1	ZSR SL	9.6	FT WSK... SBA.A...	11.6 11.1	1x 2x		
	381-1725	511-2725	E1.SE	4.2	SA.IF-N...	7.2			SBA.A...	11.1	1x	
	481-1020	231-510	E1.SE	4.2	SA.IF-N...	7.2			SBA.A...	11.1	1x	
	381-1725	1061-1485	M.500-1	9.2					SBA.A...	11.1	1x	
		1486-1735	M.750-1	9.2					SBA.A...	11.1	1x	
		1736-2235	MK.750-1	9.1	M.500-1	9.2			SBA.A...	11.1	2x	
		2236-2485	MK.750-1	9.1	M.750-1	9.2			SBA.A...	11.1	2x	
		2486-2725	MK.750-1	9.1	MK.750-1	9.1	M.500-1	9.2	SBA.A...	11.1	3x	
	481-1020	231-510	FL.IF-N...	6.1	EL.A.IF-N...	6.3						
	381-1725	511-2725	FL.IF-N...	6.1	EL.A.IF-N...	6.3						
	1041-1450	231-2725	M.500-1	9.2					SBA.A...	11.1	1x	
	1451-1725		M.750-1	9.2					SBA.A...	11.1	1x	
	381-1725	511-2725	E1	4.1					SBK.A...	11.2	1x	
	481-1020	231-510	E3	4.3					SBK.A...	11.2	1x	

Turn-tilt fitting – constant handle position

Suitable for burglary-resistant windows RC2 / RC2 N

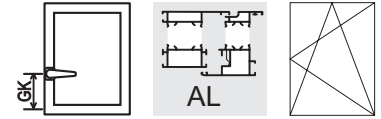

2

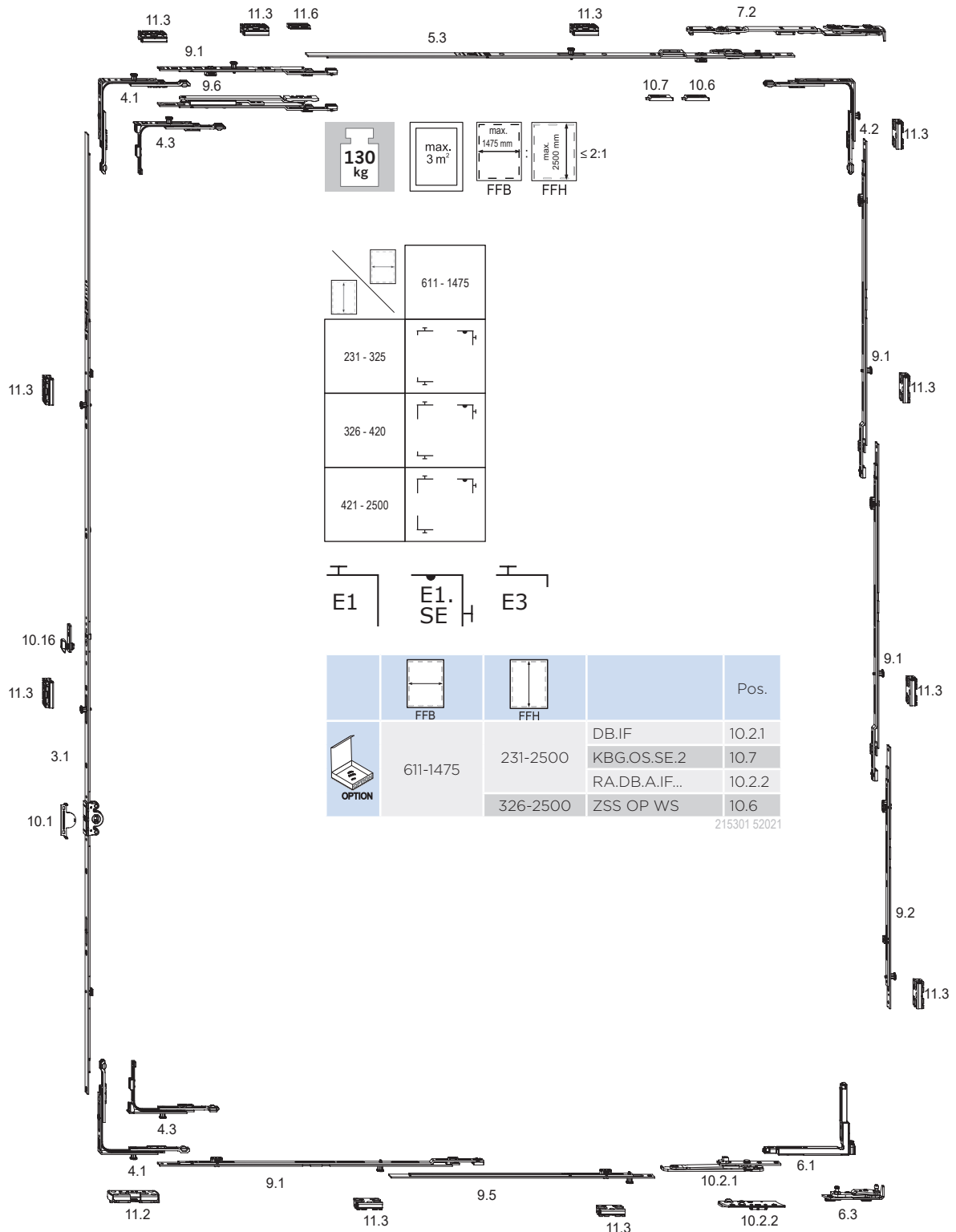







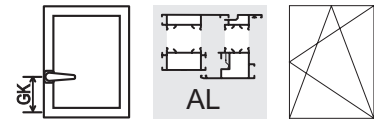



The locking distances must be agreed with the system provider.

Turn-tilt fitting – constant handle position

Suitable for burglary-resistant windows RC2 / RC2 N



				Pos.		Pos.		Pos.		Pos.	
	611-1475	231-2500	AB.G.D.15,5	10.1							
	611-840	231-420	GAK.465	3.1			GK = 114				
	611-920	421-460	GAK.465	3.1			GK = 210				
	611-1400	461-700	GAK.710	3.1			GK = 210				
	611-1475	701-850	GAK.945	3.1	FSF	10.16	GK = 260				
		851-1100	GAK.1100-1	3.1	FSF	10.16	GK = 375		SBS.A...RC	11.3	1x
		1101-1325	GAK.1325-1	3.1	FSF	10.16	GK = 550		SBS.A...RC	11.3	1x
		1326-1550	GAK.1550-1	3.1	FSF	10.16	GK = 550		SBS.A...RC	11.3	1x
		1551-1775	GAK.1775-2	3.1	FSF	10.16	GK = 550		SBS.A...RC	11.3	2x
		1776-2000	GAK.2000-2	3.1	FSF	10.16	GK = 1050		SBS.A...RC	11.3	2x
		2001-2225	GAK.2225-2	3.1	FSF	10.16	GK = 1050		SBS.A...RC	11.3	2x
		2226-2300	GAK.2225-2 MK.250-1	3.1 9.1	FSF	10.16	GK = 1050		SBS.A...RC	11.3	3x
		2301-2475	GAK.2225-2 MK.250-1	3.1 9.1	FSF	10.16	GK = 1050		SBS.A...RC	11.3	2x
2476-2500	GAK.2225-2 MK.500-1	3.1 9.1	FSF	10.16	GK = 1050		SBS.A...RC	11.3	2x		
	611-650	231-325	E3	4.3					SBS.A...RC	11.3	1x
	611-1475	326-2500	E1	4.1					SBS.A...RC	11.3	1x
	611-800	231-2500	OS.SE.800	5.3							
	801-1025		OS.SE.1025-1	5.3					SBS.A...RC	11.3	1x
	1026-1275		OS.SE.1025-1	5.3	MK.250-1	9.1			SBS.A...RC	11.3	2x
	1276-1475		OS.SE.1025-1	5.3	MK.250-1	9.1	ZSR SL	9.6	FT WSK... SBS.A...RC	11.6 11.3	1x 2x
	611-1475	231-2500	E1.SE	4.2	SA.IF-N...	7.2			SBS.A...RC	11.3	1x
	611-1475	1001-1775	M.750-1	9.2					SBS.A...RC	11.3	1x
		1776-2025	MK.750-1	9.1	M.500-1	9.2			SBS.A...RC	11.3	2x
		2026-2275	MK.750-1	9.1	M.750-1	9.2			SBS.A...RC	11.3	2x
		2276-2500	MK.750-1	9.1	MK.750-1	9.1	V.AK.450-1	9.5	SBS.A...RC	11.3	3x
	611-1475	231-2500	FL.IF-N...	6.1	EL.A.IF-N...	6.3					
	611-850	231-2500	V.AK.450-1	9.5					SBS.A...RC	11.3	1x
	851-1100		V.AK.450-1	9.5	MK.250-1	9.1			SBS.A...RC	11.3	2x
	1101-1360		V.AK.450-1	9.5	MK.500-1	9.1			SBS.A...RC	11.3	2x
	1361-1475		V.AK.450-1	9.5	MK.750-1	9.1			SBS.A...RC	11.3	2x
	611-840	231-420	E3	4.3					SBK.A...	11.2	1x
	611-1475	421-2500	E1	4.1					SBK.A...	11.2	1x

Turn-tilt fitting – central handle position

Suitable for burglary-resistant windows RC2 / RC2 N

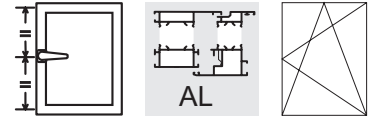

2

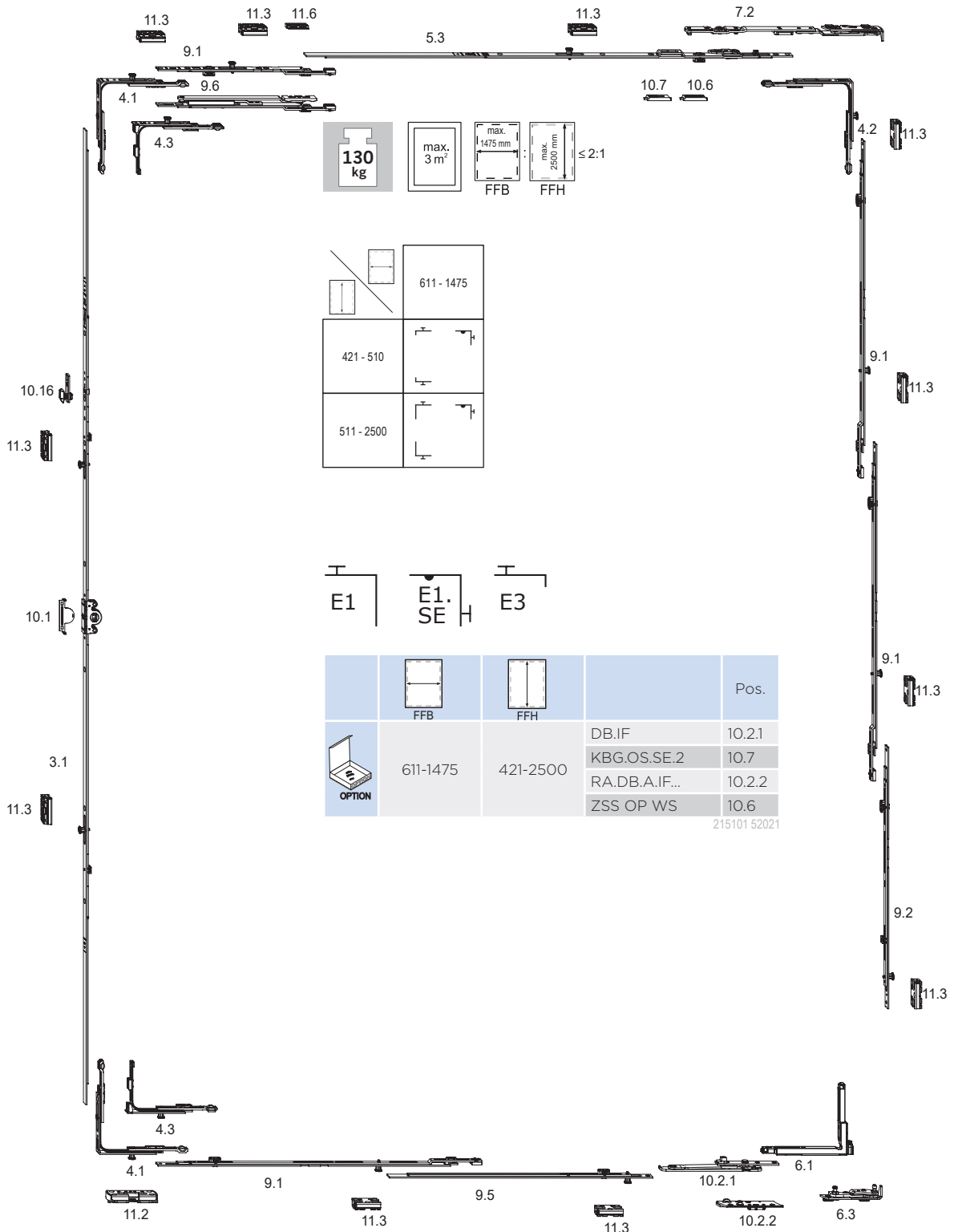







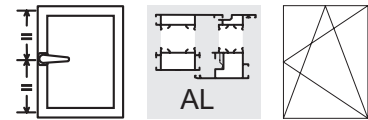



The locking distances must be agreed with the system provider.

Turn-tilt fitting – central handle position

Suitable for burglary-resistant windows RC2 / RC2 N



				Pos.		Pos.		Pos.		Pos.	
	611-1475	421-2500	AB.G.D.15,5	10.1							
	611-1400	421-700	GAM.800	3.1							
	611-1420	701-710	GAM.800	3.1	FSF	10.16					
	611-1475	711-980	GAM.1050-1	3.1	FSF	10.16			SBS.A...RC	11.3	1x
		981-1400	GAM.1400-1	3.1	FSF	10.16			SBS.A...RC	11.3	1x
		1401-1800	GAM.1800-2	3.1	FSF	10.16			SBS.A...RC	11.3	2x
		1801-2300	GAM.2300-3	3.1	FSF	10.16			SBS.A...RC	11.3	3x
2301-2500	GAM.1800-2 MK.500-1	3.1 9.1	FSF	10.16	MK.500-1	9.1		SBS.A...RC	11.3	4x	
	611-1020	421-510	E3	4.3					SBS.A...RC	11.3	1x
	611-1475	511-2500	E1	4.1					SBS.A...RC	11.3	1x
	611-800	421-2500	OS.SE.800	5.3							
	801-1025		OS.SE.1025-1	5.3					SBS.A...RC	11.3	1x
	1026-1275		OS.SE.1025-1	5.3	MK.250-1	9.1			SBS.A...RC	11.3	2x
	1276-1475		OS.SE.1025-1	5.3	MK.250-1	9.1	ZSR SL	9.6	FT WSK... SBS.A...RC	11.6 11.3	1x 2x
	611-1475	421-2500	E1.SE	4.2	SA.IF-N...	7.2			SBS.A...RC	11.3	1x
	611-1475	1001-1775	M.750-1	9.2					SBS.A...RC	11.3	1x
		1776-2025	MK.750-1	9.1	M.500-1	9.2			SBS.A...RC	11.3	2x
		2026-2275	MK.750-1	9.1	M.750-1	9.2			SBS.A...RC	11.3	2x
		2276-2500	MK.750-1	9.1	MK.750-1	9.1	V.AK.450-1	9.5		SBS.A...RC	11.3
	611-1475	421-2500	FL.IF-N...	6.1	EL.A.IF-N...	6.3					
	611-850	421-2500	V.AK.450-1	9.5					SBS.A...RC	11.3	1x
	851-1100		V.AK.450-1	9.5	MK.250-1	9.1			SBS.A...RC	11.3	2x
	1101-1360		V.AK.450-1	9.5	MK.500-1	9.1			SBS.A...RC	11.3	2x
	1361-1475		V.AK.450-1	9.5	MK.750-1	9.1			SBS.A...RC	11.3	2x
	611-1020	421-510	E3	4.3					SBK.A...	11.2	1x
	611-1475	511-2500	E1	4.1					SBK.A...	11.2	1x

Turn double sash fitting – constant handle position

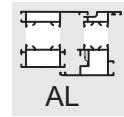

2

Basic equipment with circumferential locking points

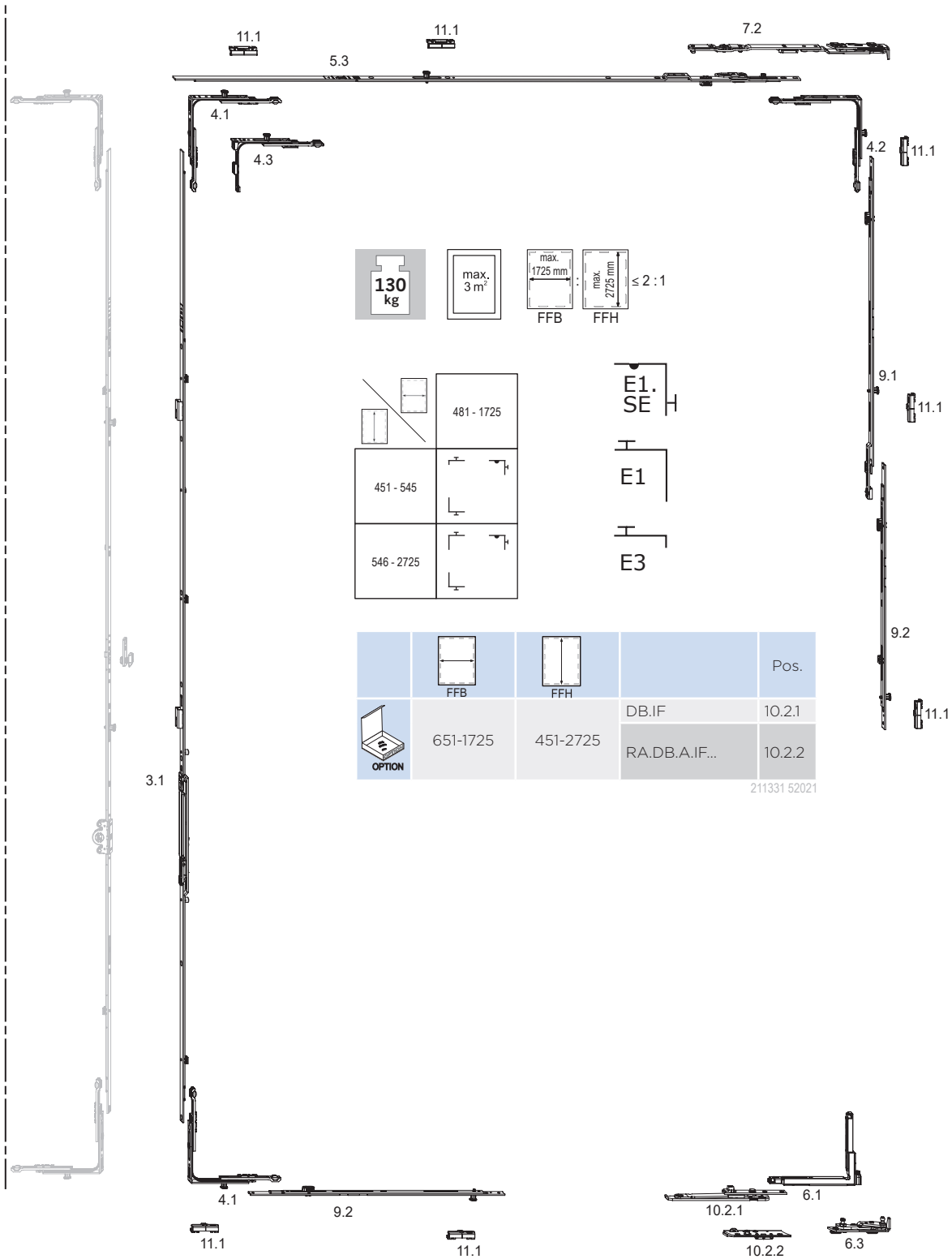







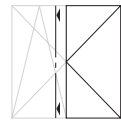
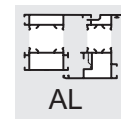



The locking distances must be agreed with the system provider.

Turn double sash fitting - constant handle position

Basic equipment with circumferential locking points



				Pos.		Pos.		Pos.		Pos.		
	481-1400	451-700	GASK.710	3.1			GK = 210					
	481-1700	701-850	GASK.945-1	3.1			GK = 260					
	481-1725	851-1100		GASK.1100-1	3.1			GK = 375				
		1101-1325		GASK.1325-1	3.1			GK = 550				
		1326-1550		GASK.1550-1	3.1			GK = 550				
		1551-1775		GASK.1775-2	3.1			GK = 550				
		1776-2000		GASK.2000-2	3.1			GK = 1050				
		2001-2225		GASK.2225-2	3.1			GK = 1050				
		2226-2475		GASK.2225-2	3.1	MS.SO.250-1	9.3	GK = 1050				
2476-2725		GASK.2225-2	3.1	MS.SO.500-1	9.3	GK = 1050						
	481-1090	451-545	E3	4.3					SBA.A...	11.1	1x	
	481-1725	546-2725	E1	4.1					SBA.A...	11.1	1x	
	481-550	451-2725	OS.SE.550	5.3								
	551-800		OS.SE.800	5.3								
	801-1025		OS.SE.1025-1	5.3					SBA.A...	11.1	1x	
	1026-1250		OS.SE.1250-1	5.3					SBA.A...	11.1	1x	
	1251-1475		OS.SE.1250-1	5.3	MK.250-0	9.1			SBA.A...	11.1	1x	
	1476-1500		OS.SE.1025-1	5.3	MK.500-1	9.1			SBA.A...	11.1	2x	
	1501-1725		OS.SE.1250-1	5.3	MK.500-1	9.1			SBA.A...	11.1	2x	
	481-1725	451-2725	E1.SE	4.2	SA.IF-N...	7.2			SBA.A...	11.1	1x	
	481-1725	1061-1485	M.500-1	9.2					SBA.A...	11.1	1x	
		1486-1735	M.750-1	9.2					SBA.A...	11.1	1x	
		1736-2235	MK.750-1	9.1	M.500-1	9.2			SBA.A...	11.1	2x	
		2236-2485	MK.750-1	9.1	M.750-1	9.2			SBA.A...	11.1	2x	
		2486-2725	MK.750-1	9.1	MK.750-1	9.1	M.500-1	9.2		SBA.A...	11.1	3x
	481-1725	451-2725	FL.IF-N...	6.1	EL.A.IF-N...	6.3						
	1041-1450	451-2725	M.500-1	9.2					SBA.A...	11.1	1x	
	1451-1725		M.750-1	9.2					SBA.A...	11.1	1x	
	481-1725	451-2725	E1	4.1					SBA.A...	11.1	1x	

Turn double-sash fitting - central handle position

Basic equipment with circumferential locking points

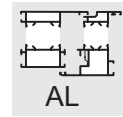

2

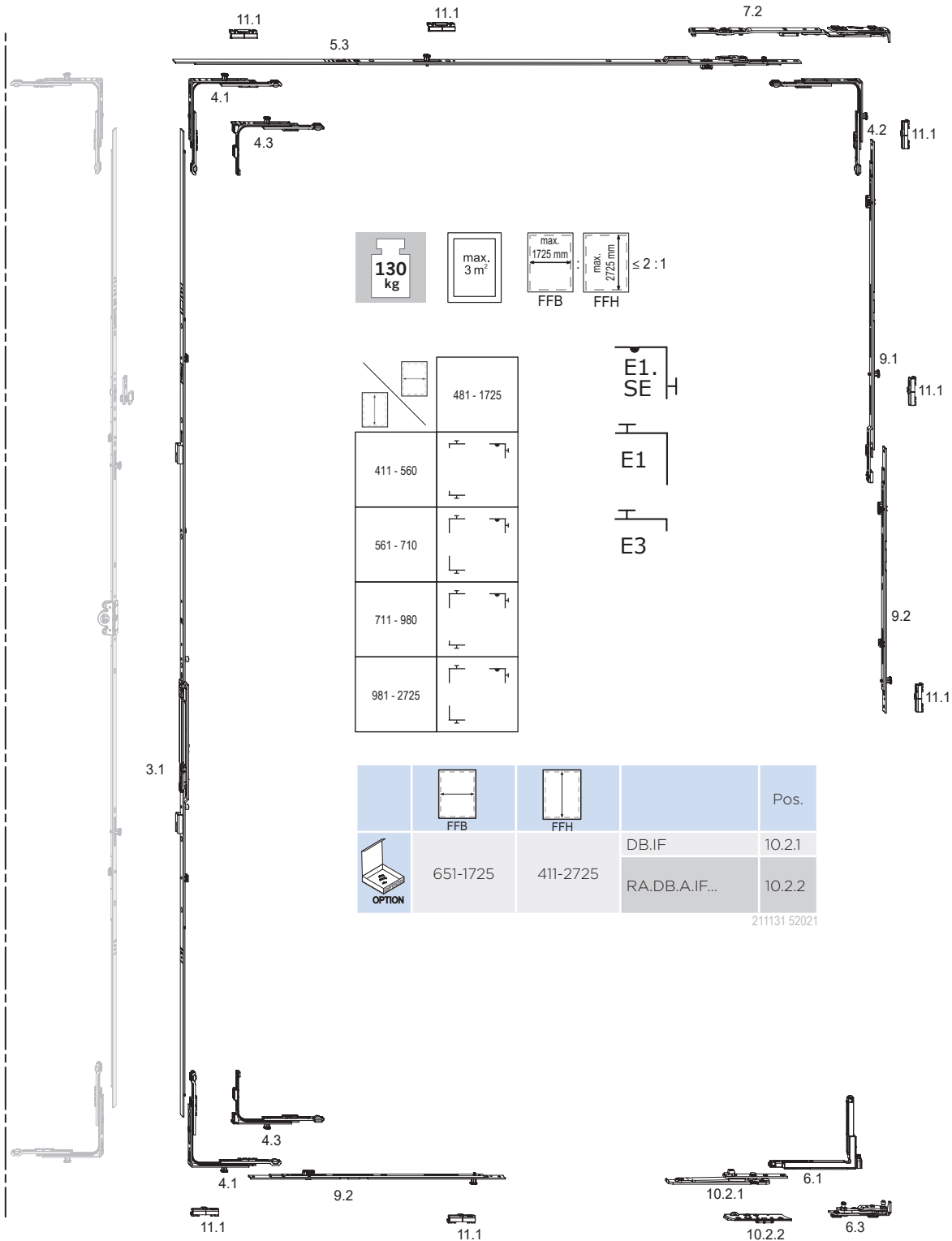







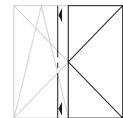
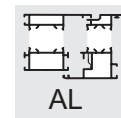



The locking distances must be agreed with the system provider.

Turn double-sash fitting – central handle position

Basic equipment with circumferential locking points



				Pos.		Pos.		Pos.		Pos.	
	481-1420	411-710	GASM.800	3.1							
	481-1725	711-980	GASM.1050-1.E3	3.1							
		981-1400	GASM.1400-1	3.1							
		1401-1800	GASM.1800-2	3.1							
		1801-2300	GASM.2300-3	3.1							
		2301-2725	GASM.2300-3	3.1	MS.SU.250-1	9.3	MS.SO.250-1	9.3			
	481-1120	411-560	E3	4.3					SBA.A...	11.1	1x
	481-1725	561-2725	E1	4.1					SBA.A...	11.1	1x
	481-550	411-2725	OS.SE.550	5.3							
	551-800		OS.SE.800	5.3							
	801-1025		OS.SE.1025-1	5.3					SBA.A...	11.1	1x
	1026-1250		OS.SE.1250-1	5.3					SBA.A...	11.1	1x
	1251-1475		OS.SE.1250-1	5.3	MK.250-0	9.1			SBA.A...	11.1	1x
	1476-1500		OS.SE.1025-1	5.3	MK.500-1	9.1			SBA.A...	11.1	2x
	1501-1725		OS.SE.1250-1	5.3	MK.500-1	9.1			SBA.A...	11.1	2x
	481-1725	411-2725	E1.SE	4.2	SA.IF-N...	7.2			SBA.A...	11.1	1x
	481-1725	1061-1485	M.500-1	9.2					SBA.A...	11.1	1x
		1486-1735	M.750-1	9.2					SBA.A...	11.1	1x
		1736-2235	MK.750-1	9.1	M.500-1	9.2			SBA.A...	11.1	2x
		2236-2485	MK.750-1	9.1	M.750-1	9.2			SBA.A...	11.1	2x
		2486-2725	MK.750-1	9.1	MK.750-1	9.1	M.500-1	9.2	SBA.A...	11.1	3x
	481-1725	411-2725	FL.IF-N...	6.1	EL.A.IF-N...	6.3					
	1041-1450	411-2725	M.500-1	9.2					SBA.A...	11.1	1x
	1451-1725		M.750-1	9.2					SBA.A...	11.1	1x
	481-1120	411-560	E3	4.3					SBA.A...	11.1	1x
	481-1420	561-710	E1	4.1					SBA.A...	11.1	1x
	481-1725	711-980	E3	4.3					SBA.A...	11.1	1x
		981-2725	E1	4.1					SBA.A...	11.1	1x

Turn double sash fitting – constant handle position

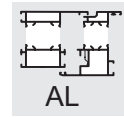

2

Basic equipment with claw bolt

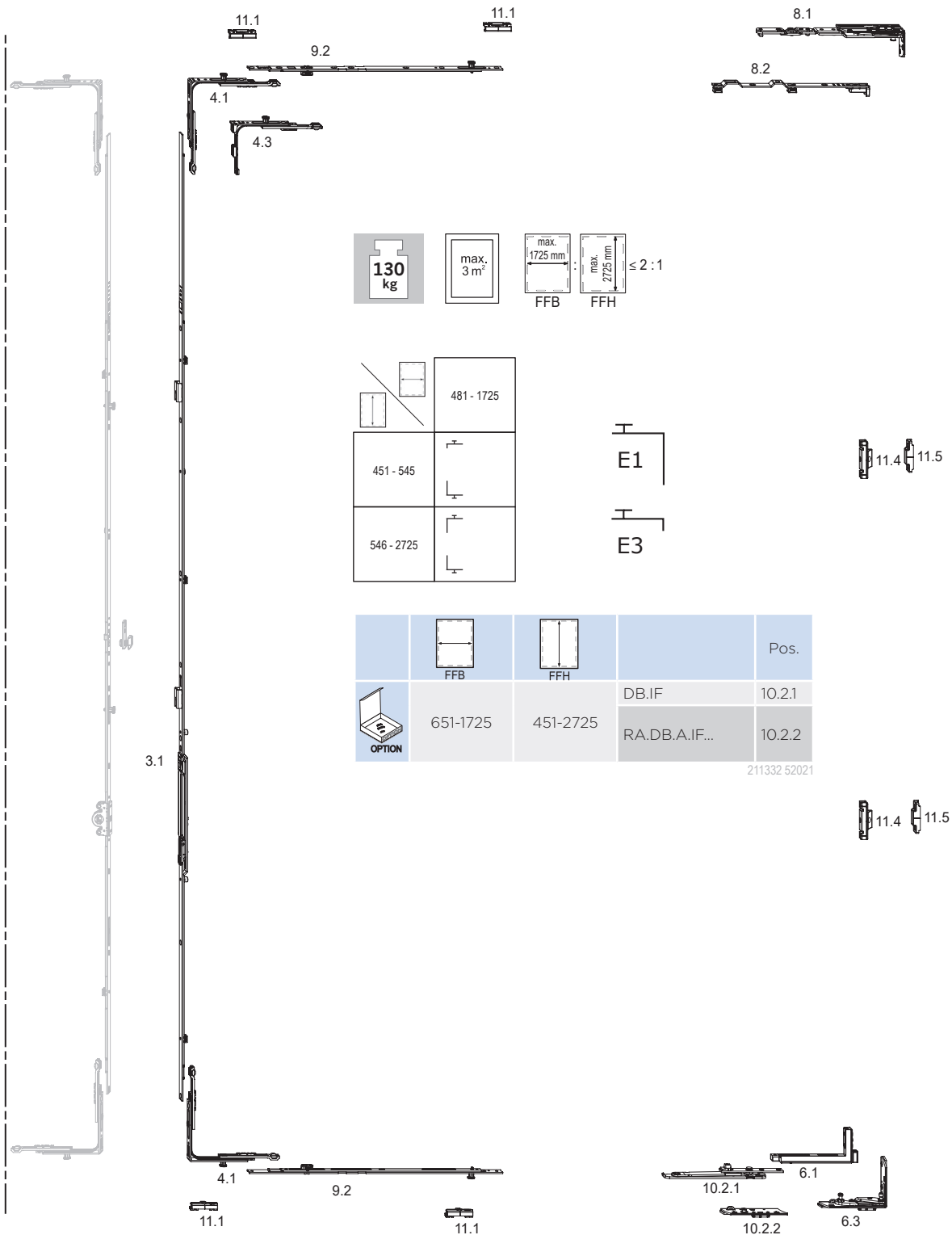







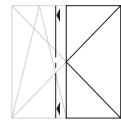
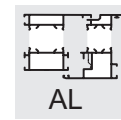



The locking distances must be agreed with the system provider.

Turn double sash fitting – constant handle position

Basic equipment with claw bolt



				Pos.		Pos.		Pos.		Pos.		
	481-1400	451-700	GASK.710	3.1			GK = 210					
	481-1700	701-850	GASK.945-1	3.1			GK = 260					
	481-1725		851-1100	GASK.1100-1	3.1			GK = 375				
			1101-1325	GASK.1325-1	3.1			GK = 550				
			1326-1550	GASK.1550-1	3.1			GK = 550				
			1551-1775	GASK.1775-2	3.1			GK = 550				
			1776-2000	GASK.2000-2	3.1			GK = 1050				
			2001-2225	GASK.2225-2	3.1			GK = 1050				
			2226-2475	GASK.2225-2	3.1	MS.SO.250-1	9.3		GK = 1050			
2476-2725	GASK.2225-2	3.1	MS.SO.500-1	9.3		GK = 1050						
	481-1090	451-545	E3	4.3					SBA.A...	11.1	1x	
	481-1725	546-2725	E1	4.1					SBA.A...	11.1	1x	
	1041-1450	451-2725	M.500-1	9.2					SBA.A...	11.1	1x	
	1451-1725		M.750-1	9.2					SBA.A...	11.1	1x	
	481-1725	451-2725	DLS.IF...	8.2								
			DL.A.IF-N...	8.1								
	481-1725	1001-2000	ZV-FT SL	11.4					ZV-RT...	99	1x	
		2001-2725	ZV-FT SL	11.4	ZV-FT SL	11.4			ZV-RT...	99	2x	
	481-1725	451-2725	FL.IF-N...	6.1	EL.A.IF-N...	6.3						
	1041-1450	451-2725	M.500-1	9.2					SBA.A...	11.1	1x	
	1451-1725		M.750-1	9.2					SBA.A...	11.1	1x	
	481-1725	451-2725	E1	4.1					SBA.A...	11.1	1x	

Turn double-sash fitting - central handle position

Basic equipment with claw bolt

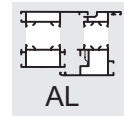

2

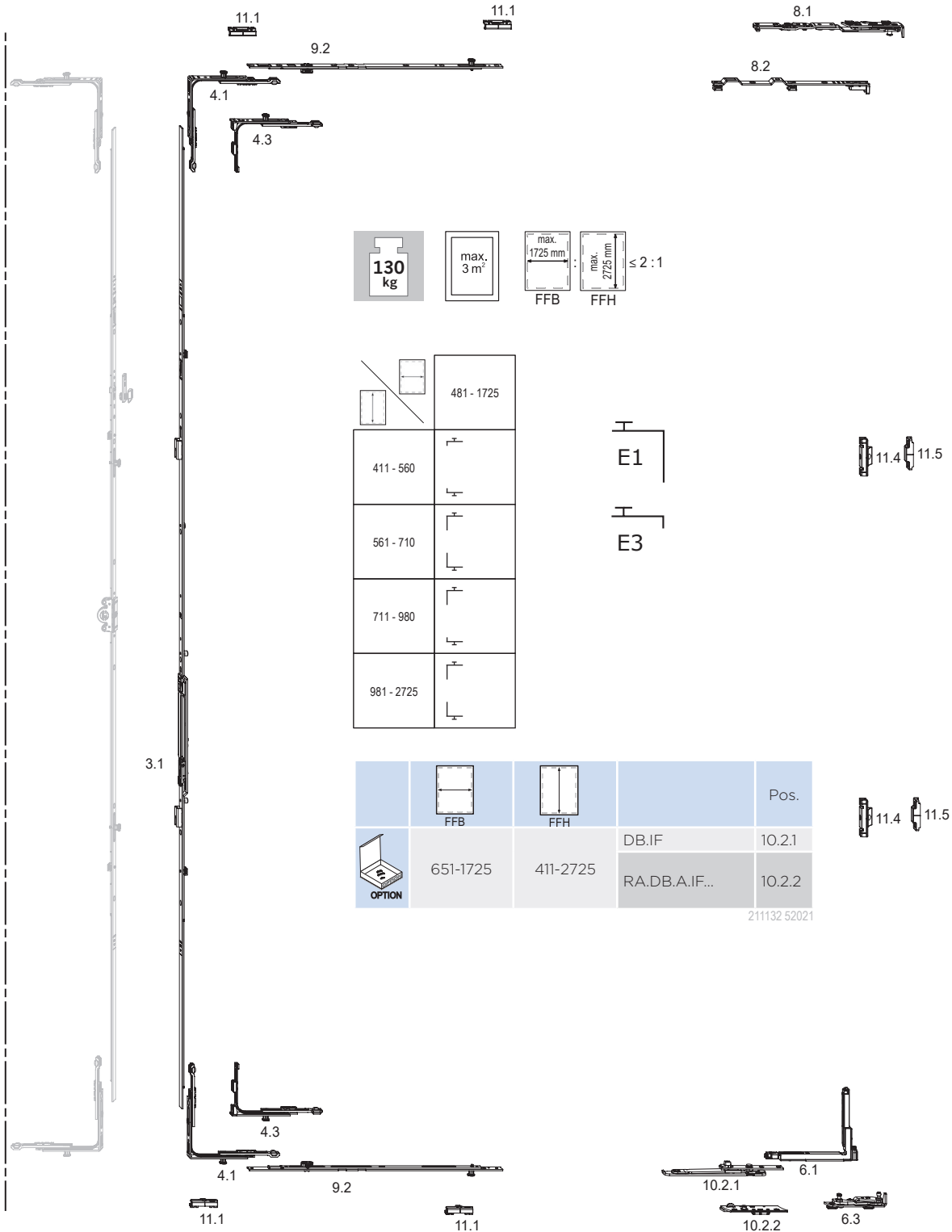

130 kg

max. 3 m²

max. 1725 mm FFB

max. 2725 mm FFH

≤ 2 : 1

		481 - 1725
411 - 560		
561 - 710		
711 - 980		
981 - 2725		



				Pos.
	651-1725	411-2725	DB,IF	10.2.1
			RA,DB,A,IF...	10.2.2

211132 52021







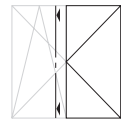
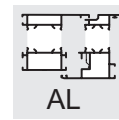



The locking distances must be agreed with the system provider.

Turn double-sash fitting – central handle position

Basic equipment with claw bolt



2

				Pos.		Pos.		Pos.		Pos.	
	481-1420	411-710	GASM.800	3.1							
	481-1725	711-980	GASM.1050-1.E3	3.1							
		981-1400	GASM.1400-1	3.1							
		1401-1800	GASM.1800-2	3.1							
		1801-2300	GASM.2300-3	3.1							
		2301-2725	GASM.2300-3	3.1	MS.SU.250-1	9.3	MS.SO.250-1	9.3			
	481-1120	411-560	E3	4.3					SBA.A...	11.1	1x
	481-1725	561-2725	E1	4.1					SBA.A...	11.1	1x
	1041-1450	411-2725	M.500-1	9.2					SBA.A...	11.1	1x
	1451-1725		M.750-1	9.2					SBA.A...	11.1	1x
	481-1725	411-2725	DLS.IF...	8.2							
			DL.A.IF-N...	8.1							
	481-1725	1001-2000	ZV-FT SL	11.4					ZV-RT...	99	1x
		2001-2725	ZV-FT SL	11.4	ZV-FT SL	11.4			ZV-RT...	99	2x
	481-1725	411-2725	FL.IF-N...	6.1	EL.A.IF-N...	6.3					
	1041-1450	411-2725	M.500-1	9.2					SBA.A...	11.1	1x
	1451-1725		M.750-1	9.2					SBA.A...	11.1	1x
	481-1120	411-560	E3	4.3					SBA.A...	11.1	1x
	481-1420	561-710	E1	4.1					SBA.A...	11.1	1x
	481-1725	711-980	E3	4.3					SBA.A...	11.1	1x
		981-2725	E1	4.1					SBA.A...	11.1	1x

Turn double sash fitting – constant handle position

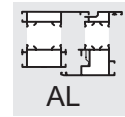

2

Suitable for burglary-resistant windows RC2 / RC2 N

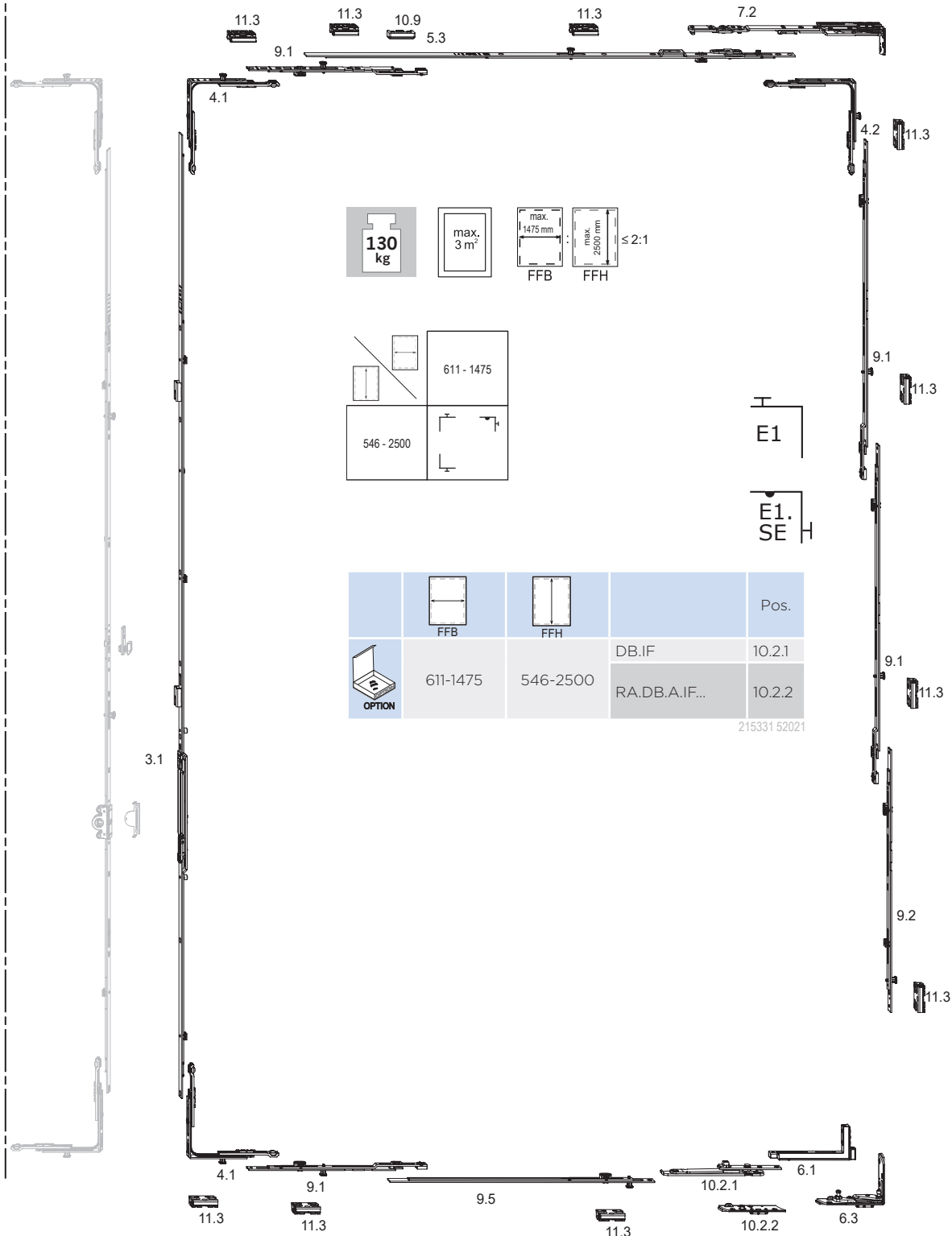

130 kg
max. 3 m²
max. 1475 mm
max. 2500 mm
≤ 2:1

FFB FFH

611 - 1475
546 - 2500

E1
E1.
SE H

				Pos.
	611-1475	546-2500	DB.IF	10.2.1
			RA.DB.A.IF...	10.2.2









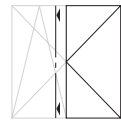
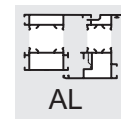

215331 52021

The locking distances must be agreed with the system provider.

Turn double sash fitting - constant handle position

Suitable for burglary-resistant windows RC2 / RC2 N



				Pos.		Pos.		Pos.		Pos.	
	611-1400	546-700	GASK.710	3.1			GK = 210				
	611-1475	701-850	GASK.945-1	3.1			GK = 260				
		851-1100	GASK.1100-1	3.1			GK = 375				
		1101-1325	GASK.1325-1	3.1			GK = 550				
		1326-1550	GASK.1550-1	3.1			GK = 550				
		1551-1775	GASK.1775-2	3.1			GK = 550				
		1776-2000	GASK.2000-2	3.1			GK = 1050				
		2001-2225	GASK.2225-2	3.1			GK = 1050				
		2226-2475	GASK.2225-2	3.1	MS.SO.250-1	9.3		GK = 1050			
2476-2500	GASK.2225-2	3.1	MS.SO.500-1	9.3		GK = 1050					
	611-1475	546-2500	E1	4.1					SBS.A...RC	11.3	1x
	611-1475	546-2500	AL D...	10.9							
	611-800		OS.SE.800	5.3							
	801-1025		OS.SE.1025-1	5.3					SBS.A...RC	11.3	1x
	1026-1275		OS.SE.1025-1	5.3	MK.250-1	9.1			SBS.A...RC	11.3	2x
	1276-1475		OS.SE.1025-1	5.3	MK.250-0	9.1	MK.250-1	9.1	SBS.A...RC	11.3	2x
	611-1475	546-2500	E1.SE	4.2	SA.IF-N...	7.2			SBS.A...RC	11.3	1x
	611-1475	1001-1775	M.750-1	9.2					SBS.A...RC	11.3	1x
		1776-2025	MK.750-1	9.1	M.500-1	9.2			SBS.A...RC	11.3	2x
		2026-2275	MK.750-1	9.1	M.750-1	9.2			SBS.A...RC	11.3	2x
		2276-2500	MK.750-1	9.1	MK.750-1	9.1	V.AK.450-1	9.5	SBS.A...RC	11.3	3x
	611-1475	546-2500	FL.IF-N...	6.1	EL.A.IF-N...	6.3					
	611-850	546-2500	V.AK.450-1	9.5					SBS.A...RC	11.3	1x
	851-1100		V.AK.450-1	9.5	MK.250-1	9.1			SBS.A...RC	11.3	2x
	1101-1360		V.AK.450-1	9.5	MK.500-1	9.1			SBS.A...RC	11.3	2x
	1361-1475		V.AK.450-1	9.5	MK.750-1	9.1			SBS.A...RC	11.3	2x
	611-1475	546-2500	E1	4.1					SBS.A...RC	11.3	1x

Turn double-sash fitting - central handle position

Suitable for burglary-resistant windows RC2 / RC2 N

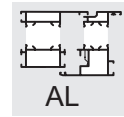

2

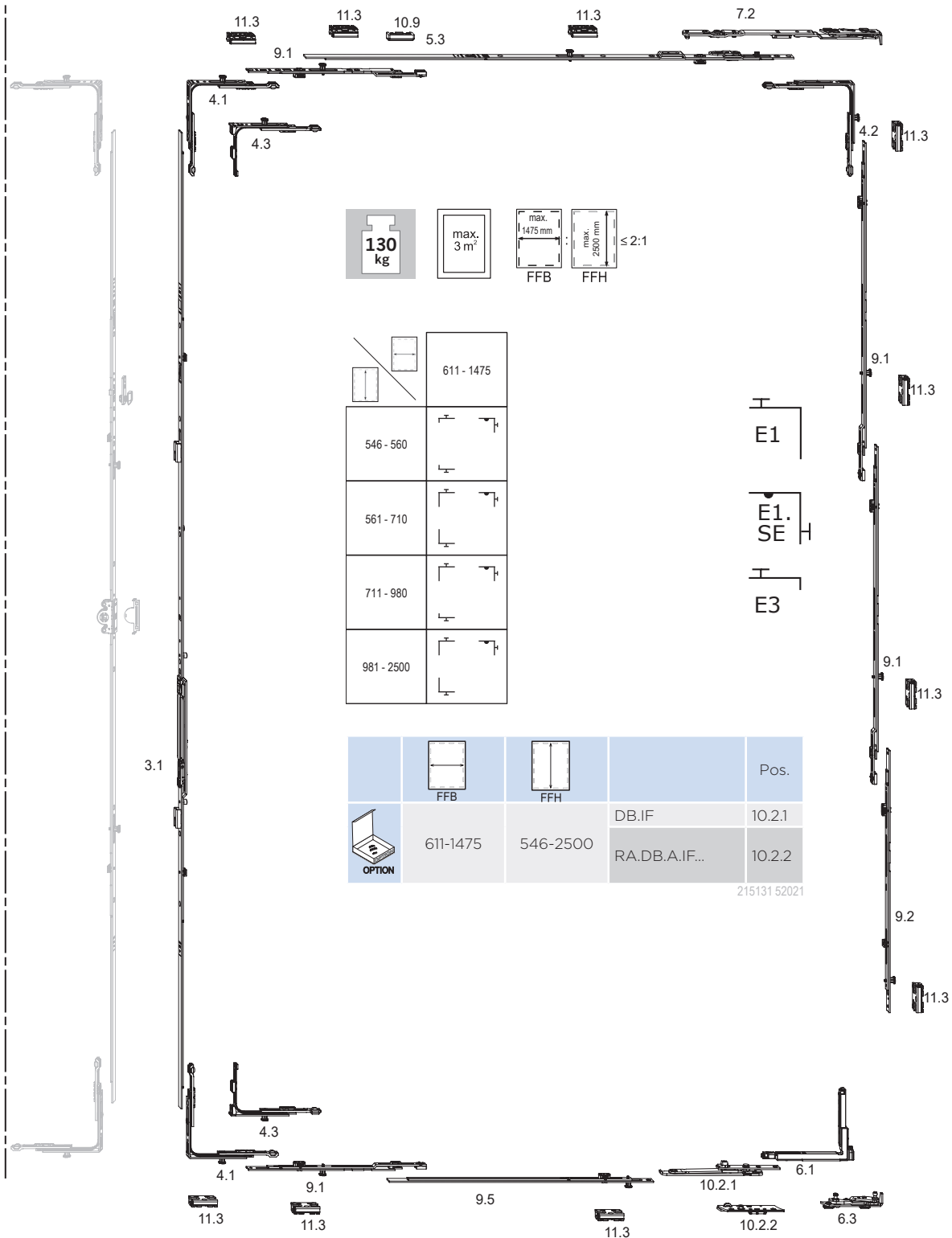







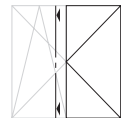
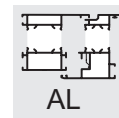



The locking distances must be agreed with the system provider.

Turn double-sash fitting – central handle position

Suitable for burglary-resistant windows RC2 / RC2 N



				Pos.		Pos.		Pos.		Pos.	
	611-1420	546-710	GASM.800	3.1							
	611-1475	711-980	GASM.1050-1.E3	3.1							
		981-1400	GASM.1400-1	3.1							
		1401-1800	GASM.1800-2	3.1							
		1801-2300	GASM.2300-3	3.1							
		2301-2500	GASM.1800-2	3.1	MS.SU.500-1	9.3	MS.SO.500-1	9.3			
	611-1120	546-560	E3	4.3					SBS.A...RC	11.3	1x
	611-1475	561-2500	E1	4.1					SBS.A...RC	11.3	1x
	611-1475	546-2500	AL D...	10.9							
	611-800		OS.SE.800	5.3							
	801-1025		OS.SE.1025-1	5.3					SBS.A...RC	11.3	1x
	1026-1275		OS.SE.1025-1	5.3	MK.250-1	9.1			SBS.A...RC	11.3	2x
	1276-1475		OS.SE.1025-1	5.3	MK.250-0	9.1	MK.250-1	9.1	SBS.A...RC	11.3	2x
	611-1475	546-2500	E1.SE	4.2	SA.IF-N...	7.2			SBS.A...RC	11.3	1x
	611-1475	1001-1775	M.750-1	9.2					SBS.A...RC	11.3	1x
		1776-2025	MK.750-1	9.1	M.500-1	9.2			SBS.A...RC	11.3	2x
		2026-2275	MK.750-1	9.1	M.750-1	9.2			SBS.A...RC	11.3	2x
		2276-2500	MK.750-1	9.1	MK.750-1	9.1	V.AK.450-1	9.5	SBS.A...RC	11.3	3x
	611-1475	546-2500	FL.IF-N...	6.1	EL.A.IF-N...	6.3					
	611-850	546-2500	V.AK.450-1	9.5					SBS.A...RC	11.3	1x
	851-1100		V.AK.450-1	9.5	MK.250-1	9.1			SBS.A...RC	11.3	2x
	1101-1360		V.AK.450-1	9.5	MK.500-1	9.1			SBS.A...RC	11.3	2x
	1361-1475		V.AK.450-1	9.5	MK.750-1	9.1			SBS.A...RC	11.3	2x
	611-1120	546-560	E3	4.3					SBS.A...RC	11.3	1x
	611-1420	561-710	E1	4.1					SBS.A...RC	11.3	1x
	611-1475	711-980	E3	4.3					SBS.A...RC	11.3	1x
		981-2500	E1	4.1					SBS.A...RC	11.3	1x

Turn-tilt fitting – constant handle position

Basic equipment – Tilt before turn

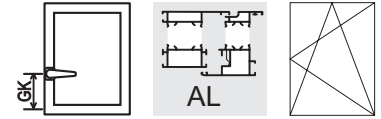

2

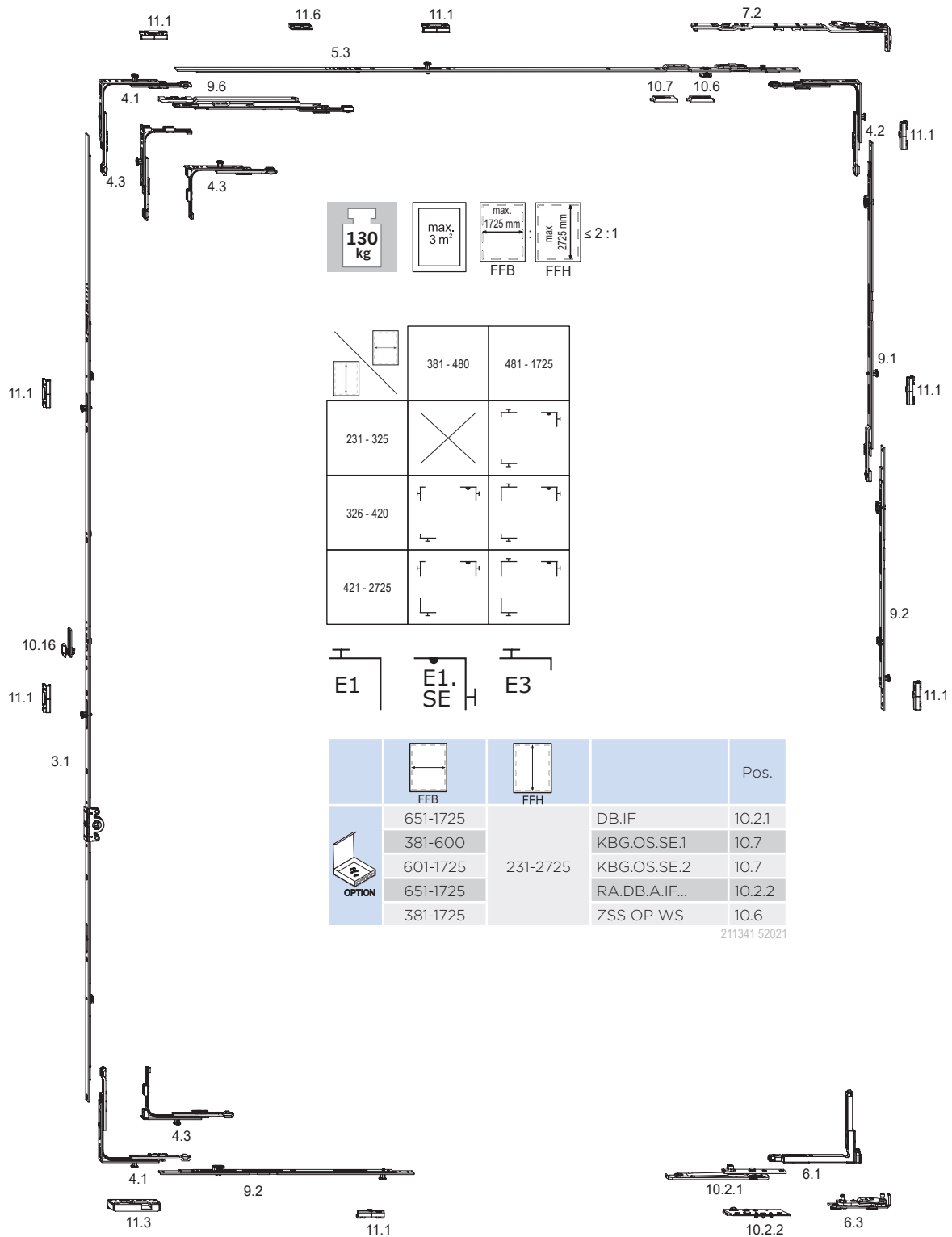







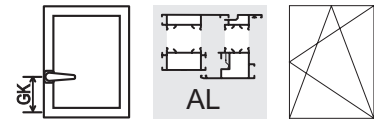



The locking distances must be agreed with the system provider.

Turn-tilt fitting – constant handle position

Basic equipment – Tilt before turn



				Pos.		Pos.		Pos.		Pos.		
	481-650	231-325	GAK.465	3.1			GK = 114					
	381-840	326-420	GAK.465	3.1			GK = 114					
	381-920	421-460	GAK.465	3.1			GK = 210					
	381-1400	461-700	GAK.710	3.1			GK = 210					
	381-1700	701-850	GAK.945	3.1	FSF	10.16	GK = 260					
	381-1725	851-1100	GAK.1100-1	3.1	FSF	10.16	GK = 375		SBA.A...	11.1	1x	
		1101-1325	GAK.1325-1	3.1	FSF	10.16	GK = 550		SBA.A...	11.1	1x	
		1326-1550	GAK.1550-1	3.1	FSF	10.16	GK = 550		SBA.A...	11.1	1x	
		1551-1775	GAK.1775-2	3.1	FSF	10.16	GK = 550		SBA.A...	11.1	2x	
		1776-2000	GAK.2000-2	3.1	FSF	10.16	GK = 1050		SBA.A...	11.1	2x	
2001-2225		GAK.2225-2	3.1	FSF	10.16	GK = 1050		SBA.A...	11.1	2x		
2226-2475		GAK.2225-2 MK.250-1	3.1 9.1	FSF	10.16	GK = 1050		SBA.A...	11.1	3x		
2476-2725	GAK.2225-2 MK.500-1	3.1 9.1	FSF	10.16	GK = 1050		SBA.A...	11.1	2x			
	381-480	326-2725	E3	4.3					SBA.A...	11.1	1x	
	481-650	231-325	E3	4.3					SBA.A...	11.1	1x	
	481-1725	326-2725	E1	4.1					SBA.A...	11.1	1x	
	381-550	326-2725	OS.SE.550.E	5.3								
	481-550	231-325	OS.SE.550.E	5.3								
	551-800		OS.SE.800.E	5.3								
	801-1025	231-2725	OS.SE.1025-1.E	5.3					SBA.A...	11.1	1x	
	1026-1250		OS.SE.1250-1.E	5.3					SBA.A...	11.1	1x	
	1251-1475		OS.SE.1250-1.E	5.3	MK.250-0	9.1				SBA.A...	11.1	1x
	1476-1500		OS.SE.1025-1.E	5.3	MK.250-1	9.1	ZSRE SL	9.6	FT WSK... SBA.A...	11.6 11.1	1x 2x	
1501-1725	OS.SE.1250-1.E	5.3	MK.250-1	9.1	ZSRE SL	9.6	FT WSK... SBA.A...	11.6 11.1	1x 3x			
	381-1725	326-2725	E1.SE	4.2	SA.IF-N.E...	7.2			SBA.A...	11.1	1x	
	481-650	231-325	E1.SE	4.2	SA.IF-N.E...	7.2			SBA.A...	11.1	1x	
	381-1725	1061-1485	M.500-1	9.2					SBA.A...	11.1	1x	
		1486-1735	M.750-1	9.2					SBA.A...	11.1	1x	
		1736-2235	MK.750-1	9.1	M.500-1	9.2				SBA.A...	11.1	2x
		2236-2485	MK.750-1	9.1	M.750-1	9.2				SBA.A...	11.1	2x
		2486-2725	MK.750-1	9.1	MK.750-1	9.1	M.500-1	9.2		SBA.A...	11.1	3x
	481-650	231-325	FL.IF-N...	6.1	EL.A.IF-N...	6.3						
	381-1725	326-2725	FL.IF-N...	6.1	EL.A.IF-N...	6.3						
	1041-1450	231-2725	M.500-1	9.2					SBA.A...	11.1	1x	
	1451-1725		M.750-1	9.2					SBA.A...	11.1	1x	
	381-840	326-420	E3	4.3					SBK.A...	11.2	1x	
	381-1725	421-2725	E1	4.1					SBK.A...	11.2	1x	
	481-650	231-325	E3	4.3					SBK.A...	11.2	1x	

In case of sash rebate heights (FFH) of < 701 mm it is not possible to install a fail-safe device directly onto the drive rod. By combining a shorter drive rod with an MK.250.FSF interlocking rod, the required fail-safe device can be integrated from a sash rebate height of > 475 mm.

Turn-tilt fitting – central handle position

Basic equipment – Tilt before turn

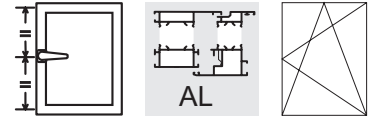

2

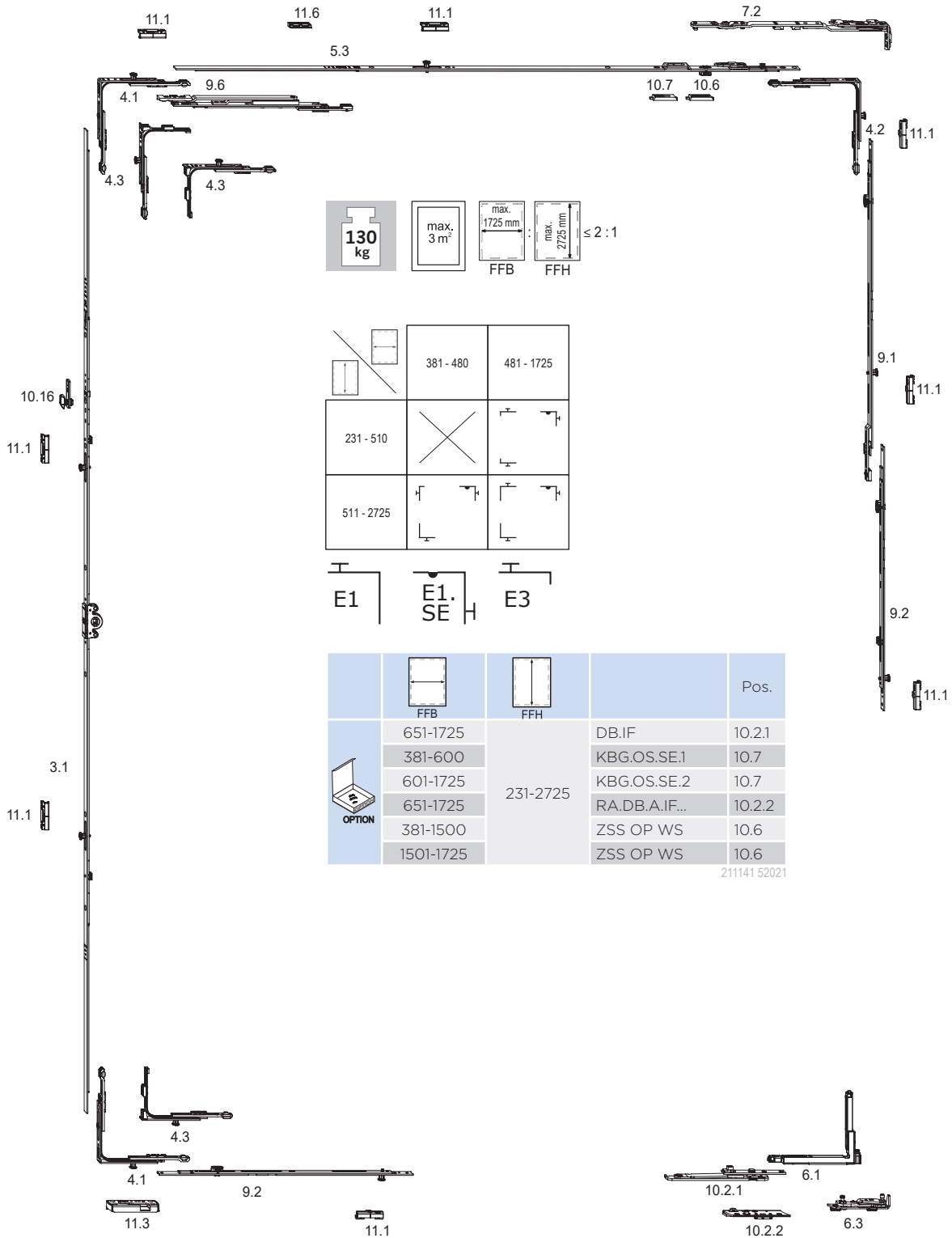

The locking distances must be agreed with the system provider.

Turn-tilt fitting – central handle position

Basic equipment – Tilt before turn

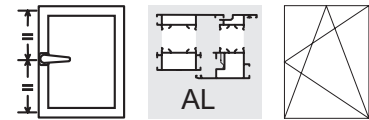

				Pos.		Pos.		Pos.		Pos.	
	481-650	231-325	GAK.465	3.1			GK = 114				
	481-1020	326-510	GAM.800	3.1							
	381-1420	511-710	GAM.800	3.1							
	381-1725	711-980	GAM.1050	3.1	FSF	10.16					
		981-1400	GAM.1400-1	3.1	FSF	10.16			SBA.A...	11.1	1x
		1401-1800	GAM.1800-2	3.1	FSF	10.16			SBA.A...	11.1	2x
		1801-2300	GAM.2300-3	3.1	FSF	10.16			SBA.A...	11.1	3x
2301-2725	GAM.2300-3	3.1	FSF	10.16	MK.250-1	9.1	SBA.A...	11.1	5x		
		MK.250-1	9.1								
	381-480	511-2725	E3	4.3					SBA.A...	11.1	1x
	481-1020	231-510	E3	4.3					SBA.A...	11.1	1x
	481-1725	511-2725	E1	4.1					SBA.A...	11.1	1x
	381-550	511-2725	OS.SE.550.E	5.3							
	481-550	231-510	OS.SE.550.E	5.3							
	551-800	231-2725	OS.SE.800.E	5.3							
	801-1025		OS.SE.1025-1.E	5.3					SBA.A...	11.1	1x
	1026-1250		OS.SE.1250-1.E	5.3					SBA.A...	11.1	1x
	1251-1475		OS.SE.1250-1.E	5.3	MK.250-0	9.1			SBA.A...	11.1	1x
	1476-1500		OS.SE.1025-1.E	5.3	MK.250-1	9.1	ZSRE SL	9.6	FT WSK... SBA.A...	11.6 11.1	1x 2x
1501-1725	OS.SE.1250-1.E	5.3	MK.250-1	9.1	ZSRE SL	9.6	FT WSK... SBA.A...	11.6 11.1	1x 2x		
	381-1725	511-2725	E1.SE	4.2	SA.IF-N.E...	7.2			SBA.A...	11.1	1x
	481-1020	231-510	E1.SE	4.2	SA.IF-N.E...	7.2			SBA.A...	11.1	1x
	381-1725	1061-1485	M.500-1	9.2					SBA.A...	11.1	1x
		1486-1735	M.750-1	9.2					SBA.A...	11.1	1x
		1736-2235	MK.750-1	9.1	M.500-1	9.2			SBA.A...	11.1	2x
		2236-2485	MK.750-1	9.1	M.750-1	9.2			SBA.A...	11.1	2x
		2486-2725	MK.750-1	9.1	MK.750-1	9.1	M.500-1	9.2	SBA.A...	11.1	3x
	481-1020	231-510	FL.IF-N...	6.1	EL.A.IF-N...	6.3					
	381-1725	511-2725	FL.IF-N...	6.1	EL.A.IF-N...	6.3					
	1041-1450	231-2725	M.500-1	9.2					SBA.A...	11.1	1x
	1451-1725		M.750-1	9.2					SBA.A...	11.1	1x
	381-1725	511-2725	E1	4.1					SBK.A...	11.2	1x
	481-1020	231-510	E3	4.3					SBK.A...	11.2	1x

In case of sash rebate heights (FFH) of < 711 mm it is not possible to install a fail-safe device directly onto the drive rod. By combining a shorter drive rod with an MK.250.FSF interlocking rod, the required fail-safe device can be integrated from a sash rebate height of > 475 mm.

Tilt fanlight

Basic equipment

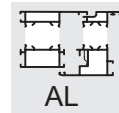

2

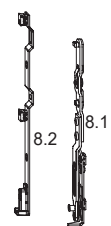
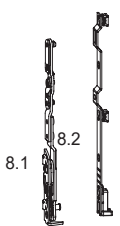
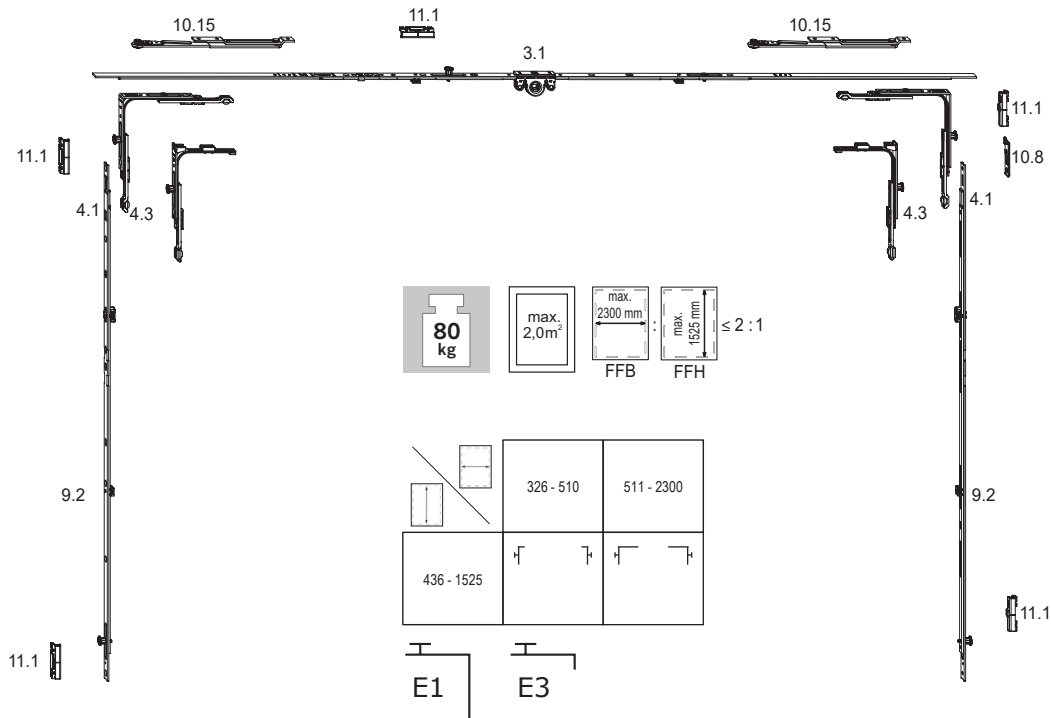







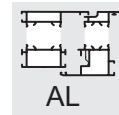

The locking distances must be agreed with the system provider.

Tilt fanlight

Basic equipment



				Pos.		Pos.		Pos.		Pos.	
	326-710	436-1525	GAM.800	3.1	GRT FSR SL	10.15					
	711-1050		GAM.1050-1	3.1	GRT FSR SL	10.15			SBA.A...	11.1	1x
	1051-1400		GAM.1400-1	3.1	GRT FSR SL	10.15	GRT FSR SL	10.15	SBA.A...	11.1	1x
	1401-1800		GAM.1800-2	3.1	GRT FSR SL	10.15	GRT FSR SL	10.15	SBA.A...	11.1	2x
	1801-2300		GAM.2300-3	3.1	GRT FSR SL	10.15	GRT FSR SL	10.15	SBA.A...	11.1	3x
	326-510	436-1525	E3	4.3					SBA.A...	11.1	1x
	511-2300		E1	4.1					SBA.A...	11.1	1x
	326-2300	436-1525	DLS.IF...	8.2							
		436-1060	DL.A.IF-N...LS	8.1							
		1061-1485	M.500-1	9.2	DL.A.IF-N...LS	8.1			SBA.A...	11.1	1x
		1486-1525	M.750-1	9.2	DL.A.IF-N...LS	8.1			SBA.A...	11.1	1x
	741-1480	436-1525	ZV-FT SL	11.4					ZV-RT...	99	1x
	1481-2300		ZV-FT SL	11.4	ZV-FT SL	11.4			ZV-RT...	99	2x
	326-2300	436-1525	DLS.IF...	8.2							
		436-1060	DL.A.IF-N...RS	8.1							
		1061-1485	M.500-1	9.2	DL.A.IF-N...RS	8.1			SBA.A...	11.1	1x
		1486-1525	M.750-1	9.2	DL.A.IF-N...RS	8.1			SBA.A...	11.1	1x
	326-2300	436-1525	AWDR SL	10.8							
	326-510		E3	4.3					SBA.A...	11.1	1x
	511-2300		E1	4.1					SBA.A...	11.1	1x

211151 52021

- To secure the tilting sash in 90° opening position, or during cleaning, the window must also be fitted with standard cleaning or supporting shears.
- The sashes must be secured in the cleaning position in such a way that no unacceptable forces are exerted on the hinges.
- After cleaning the window, the rebate shear must be properly attached and secured.
- Close windows in case of wind and draft. Move the fitting to locking position

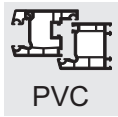

PVC

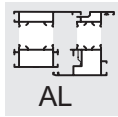

AL

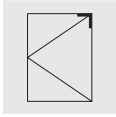
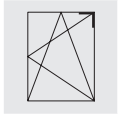

4

Corner drive E1.SE.N

- Utilisation in combination with the shears
SH.SE / SA.SE / SK.SE and SH.IF / SA.IF / SK.IF
- Bracket length 98.5 mm
- Automatic and manual assembly possible
- Smooth operation, due to rust-free spring steel hinges inserted in C-rail
- With supporting element to fix in the fitting groove of the sash

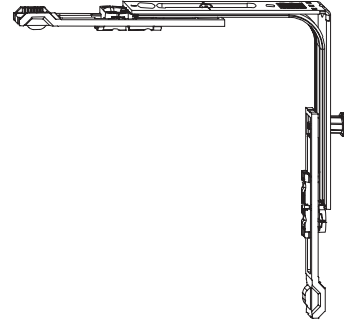

E1.SE.N

Item designation	Item no.		VPA1 Pcs/type	VPA2 Pcs/type
E1.SE.N	5060652	4	100 KK	2400 EK

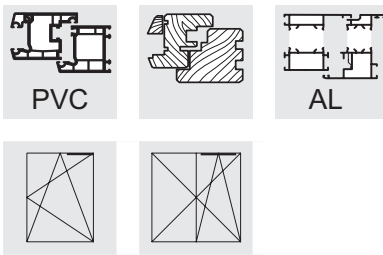

Top rod OS.SE

- In combination with shears S...SE / S...IF / S...IF-N
- After assembly the top rod and the shear are firmly attached to one another
- From 1475 mm sash rebate width with additional shear ZSR
- Clampable in fitting groove

Top rod OS.SE...E

- For the type of fitting "Tilt before turn"
- In combination with shears S...SE.E / S...IF.E / S...IF-N.E
- From 1475 mm sash rebate width with additional shear ZSRE
- Other details regarding the design see above

Item designation	Item no.	Application range		VPA1 Qty./Type	VPA2 Qty./Type
OS.SE.550	4934243	FFB 480 - 550	3	20 BD	800 EA
OS.SE.800	4934244	FFB 550 - 800	4	20 BD	800 EA
OS.SE.1025-1	4934245	FFB 775 - 1025	5	20 BD	500 EA
OS.SE.1250-1	4934246	FFB 1000 - 1250	6	20 BD	500 EA
OS.SE.550.E	5003250	FFB 480 - 550	3	20 BD	800 EA
OS.SE.800.E	5003251	FFB 550 - 800	4	20 BD	800 EA
OS.SE.1025-1.E	5003252	FFB 775 - 1025	5	20 BD	500 EA
OS.SE.1250-1.E	5003253	FFB 1000 - 1250	6	20 BD	500 EA

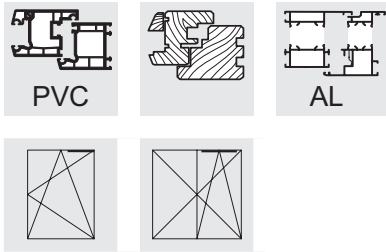

5

Top rod OS.SE...E1.SE.F

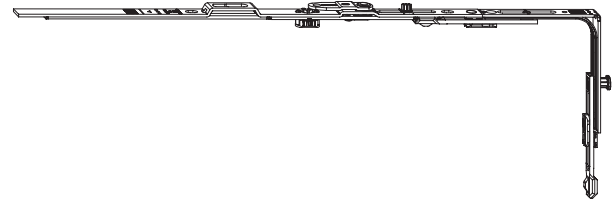

- Top rod OS.SE... with pre-connected E1.SE for efficient assembly by means of screwing machines
- In combination with shears S...SE / S...IF / S...IF-N
- After assembly the top rod and the shear are firmly attached to one another
- From 1475 mm sash rebate width with additional shear ZSR

Top rod OS.SE...E1.ZSS

- With pre-assembled anti-slam device

Top rod OS.SE...E.ZSS.E1.SE.F

- For the type of fitting "Tilt before turn"
- With pre-assembled anti-slam device
- In combination with shears S...SE.E / S...IF.E / S...IF-N.E
- From 1475 mm sash rebate width with additional shear ZSRE

Item designation	Item no.	Application range		VPA1 Qty./Type	VPA2 Qty./Type
OS.SE.550.E1.SE.F	4942498	FFB 480 - 550	5	10 BD	400 EA
OS.SE.800.E1.SE.F	4942499	FFB 550 - 800	5	10 BD	400 EA
OS.SE.1025-1.E1.SE.F	4942500	FFB 775 - 1025	6	10 BD	400 EA
OS.SE.1250-1.E1.SE.F	4942501	FFB 1000 - 1250	6	10 BD	400 L1
OS.SE.550.E1.SE.ZSS.F	5025778	FFB 480 - 550	5	10 BD	400 EA
OS.SE.800.E1.SE.ZSS.F	5025779	FFB 550 - 800	5	10 BD	400 EA
OS.SE.1025-1.E1.SE.ZSS.F	5025780	FFB 775 - 1025	6	10 BD	400 EA
OS.SE.1250-1.E1.SE.ZSS.F	5025781	FFB 1000 - 1250	6	10 BD	400 L1
OS.SE.550.E.ZSS.E1.SE.F	5049407	FFB 480 - 550	5	10 BD	400 EA
OS.SE.800.E.ZSS.E1.SE.F	5049409	FFB 550 - 800	5	10 BD	400 EA
OS.SE.1025-1.E.ZSS.E1.SE.F	5049411	FFB 775 - 1025	6	10 BD	400 EA
OS.SE.1250-1.E.ZSS.E1.SE.F	5049412	FFB 1000 - 1250	6	10 BD	400 L1

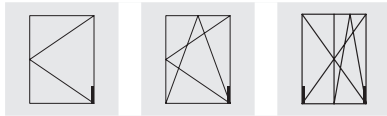
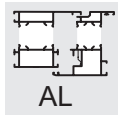

Corner hinges EL.A.IF-N

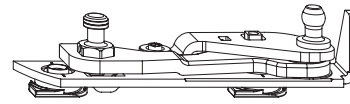

- In combination with sash hinge FL.IF-N
- Pressure adjustment: +/- 0.8 mm
- Sash weight max. 130 kg
- Max. Opening angle 90°
- Easy assembly thanks to profile adjustment
- Clampable with bayonet bolt
- Installation specifications see Installation Instructions

Note:

- The overview of profile allocation for the individual items is illustrated at the beginning of the chapter 2 "Fittings lists".

Item designation	Item no.	Max. sash weight (kg)	VPA1 Qty./Type	VPA2 Qty./Type
EL.A.IF-N.74.RS	5102987	130	50 KK	400 EK
EL.A.IF-N.74.LS	5102988	130	50 KK	400 EK
EL.A.IF-N.75.RS	5102989	130	50 KK	400 EK
EL.A.IF-N.75.LS	5102990	130	50 KK	400 EK
EL.A.IF-N.78.RS	5102991	130	50 KK	400 EK
EL.A.IF-N.78.LS	5102992	130	50 KK	400 EK
EL.A.IF-N.87.RS	5102993	130	50 KK	400 EK
EL.A.IF-N.87.LS	5102994	130	50 KK	400 EK

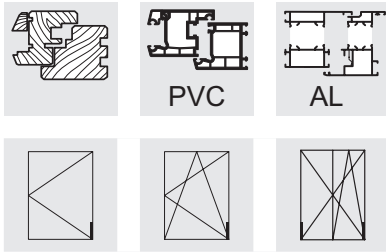

Sash hinges FL.IF-N

6

- Sash weight max. 130 kg
- Height adjustment +2 mm / -1.5 mm
- Side adjustment +2.5 mm / -1.5 mm
- Used in combination with corner hinge EL...IF

Sash hinge FL.IF-N.C

- As described above, but as clampable version for automatic screwing

Sash hinge FL.IF-N.24-9

- As described above, but for 9 mm groove centre position
- Can be used left and right hand

Sash hinge FL.IF-N.C.ALU

- As described above, but with long leg

FL.IF-N.C.ALU.24-9.74

- As described above, but for 13 mm airgap

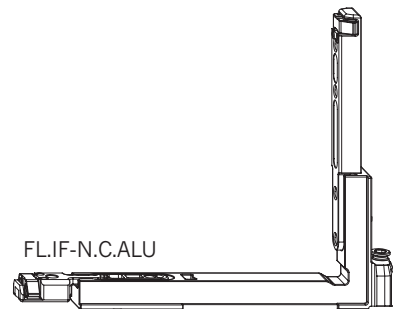

Item designation	Item no.		Max. sash weight (kg)	Groove centre position	VPA1 Qty./Type	VPA2 Qty./Type
FL.IF-N.ALU.9.SPW	5103023	4	130	9 mm	50 KK	400 EK
FL.IF-N.C.ALU.9.74	5103024	4	130	9 mm	50 KK	400 EK
FL.IF-N.C.ALU.9	5103025	4	130	9 mm	50 KK	400 EK
FL.IF-N.C.ALU.RS	5103027	4	130	13 mm	50 KK	400 EK
FL.IF-N.C.ALU.LS	5103028	4	130	13 mm	50 KK	400 EK

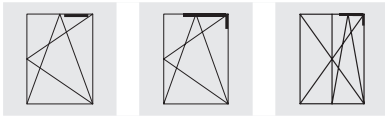
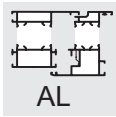

Shears SA.IF-N

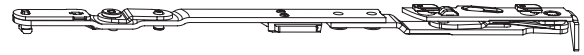

- When sash is closed, it is completely concealed with no hinges visible
- Only one shear size
- Max. Opening angle 90°
- Used with Top Rod OS.SE
- Contact pressure for shear is adjusted via E1.SE
- Adjustment to raise the sash 2.5 mm and lower it 1.5 mm
- Clampable with bayonet bolt
- Installation specifications see Installation Instructions

7

Shear SA.IF-N.E...

- Tilt before turn
- Used in combination with top rod OS.SE.E

Note

- The overview of profile allocation for the individual items is illustrated at the beginning of the chapter 2 "Fittings lists".

Item designation	Item no.	Max. sash weight (kg)	VPA1 Qty./Type	VPA2 Qty./Type	VPA3 Qty./Type
SA.IF-N.74.RS	5102996	130	10 BD	60 GK	240 EK
SA.IF-N.74.LS	5103004	130	10 BD	60 GK	240 EK
SA.IF-N.75.RS	5103005	130	10 BD	60 GK	240 EK
SA.IF-N.75.LS	5103006	130	10 BD	60 GK	240 EK
SA.IF-N.78.RS	5103007	130	10 BD	60 GK	240 EK
SA.IF-N.78.LS	5103008	130	10 BD	60 GK	240 EK
SA.IF-N.87.RS	5103009	130	10 BD	60 GK	240 EK
SA.IF-N.87.LS	5103010	130	10 BD	60 GK	240 EK
SA.IF-N.E.75.RS	5103011	130	10 BD	60 GK	240 EK
SA.IF-N.E.75.LS	5103012	130	10 BD	60 GK	240 EK
SA.IF-N.E.87.RS	5103013	130	10 BD	60 GK	240 EK
SA.IF-N.E.87.LS	5103014	130	10 BD	60 GK	240 EK

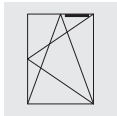
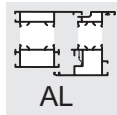
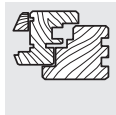
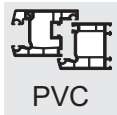

Additional shear ZSR SL

- Airgap 12 mm
- Overlap 18 to 22 mm
- For width FFB > 1475 mm
- Screw-connect-type frame plate preadjusted for insertion of WSK part (profile-dependent, see Group 11)
- Installation situation see Group 15, installation drawings B-7-4
- Profile adaption using adapters FT - WSK see group Frame Parts

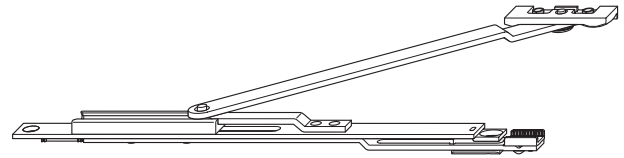

7

Additional shear ZSRE SL

- Use in turn-tilt windows with operating sequence tilt before turn
- In all other respects construction is the same as additional shear ZSR
- Installation situation see group 15, installation drawings B-7-5

Item description	Item No.	Scope of application		VPA1 Qty./Type	VPA2 Qty./Type	VPA3 Qty./Type
ZSR SL	5048941	FFB > 1475	4	10 BD	80 KK	640 EK
ZSRE SL	5048946	FFB > 1475	4	10 BD	80 KK	640 EK

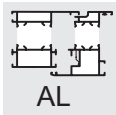

AL

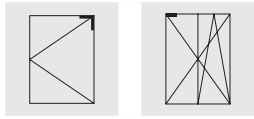
New
Version

Turn hinge DL.A.IF-N

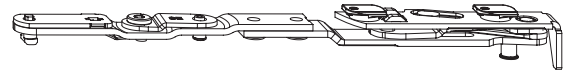

- Installation on the frame
- Used to hold the turn hinge rail DLS.IF
- When sash is closed, it is completely concealed with no hinges visible
- Max. Opening angle 90°
- Adjustment to raise the sash 2.5 mm and lower it 1.5 mm
- Easy assembly thanks to profile adjustment
- Clampable with bayonet bolt
- Installation specifications see Installation Instructions

Note

- The overview of profile allocation for the individual items is illustrated at the beginning of the chapter 2 "Fittings lists".

8

Item designation	Item no.	Max. sash weight (kg)	VPA1 Qty./Type	VPA2 Qty./Type	VPA3 Qty./Type
DL.A.IF-N.74.RS	5103015	130	10 BD	60 GK	240 EK
DL.A.IF-N.74.LS	5103016	130	10 BD	60 GK	240 EK
DL.A.IF-N.75.RS	5103017	130	10 BD	60 GK	240 EK
DL.A.IF-N.75.LS	5103018	130	10 BD	60 GK	240 EK
DL.A.IF-N.78.RS	5103019	130	10 BD	60 GK	240 EK
DL.A.IF-N.78.LS	5103020	130	10 BD	60 GK	240 EK
DL.A.IF-N.87.RS	5103021	130	10 BD	60 GK	240 EK
DL.A.IF-N.87.LS	5103022	130	10 BD	60 GK	240 EK

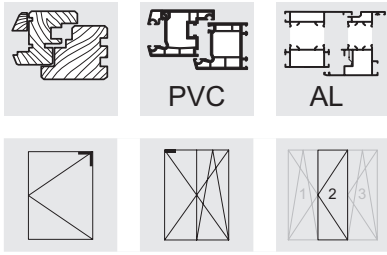

Turn hinge rail DLS.IF

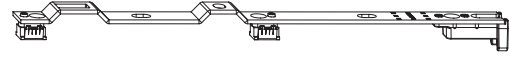

- Used with turn hinge DL...IF-N
- Can be used left and right hand
- Clampable in fitting groove
- Groove centre position 9 mm and 13 mm

8

Item designation	Item no.		VPA1 Pcs/type	VPA2 Pcs/type	VPA3 Pcs/type
DLS.IF.24-13	5018332	3	10 BD	100 KK	800 EK

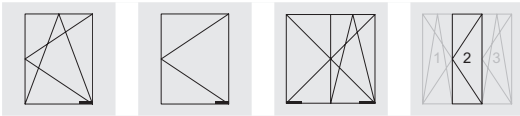
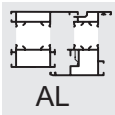

Turn limiter DB.IF.74/75/78

- To prevent window opening too far sideways
- For 9 and 13 mm eurogroove position
- Used with frame connection RA.DB.A.IF... (acc. to table)
- See Installation Instructions for range of applications of turn limiter
- Can be used left and right hand
- Designed for horizontal airgaps 12 mm (+ 1 mm)

Note

- Use of the turn limiter depending on installation situation
- Using the turn limiter is imperative if:
Reveal depth of surrounding masonry < 120 mm (DIN EN 13126-8, Point 4)

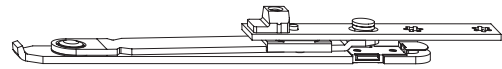

EL...	RA.DB...	DB.IF...
EL.A.IF-N.74	RA.DB.A.IF-N.74	DB.IF.74/75/78
EL.A.IF-N.75	RA.DB.A.IF-N.75	DB.IF.74/75/78
EL.A.IF-N.78	RA.DB.A.IF-N.78	DB.IF.74/75/78
EL.A.IF-N.87	RA.DB.A.IF-N.75	DB.IF.74/75/78

Item designation	Item no.	 Qty.	Airgap	Groove centre position	VPA1 Qty./Type	VPA2 Qty./Type	VPA3 Qty./Type
DB.IF.74/75/78	5086352	2	12	9 / 13	10 BD	100 KK	800 EK

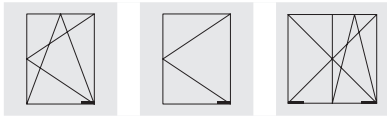
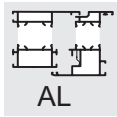

Frame connection RA.DB.A.IF-N

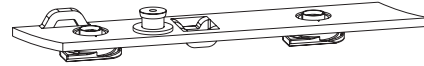

- Used with turn limiter DB.IF.74/75/78
- See Installation Instructions for range of applications of turn limiter
- Easy assembly thanks to profile adjustment
- Clampable with bayonet bolt
- Installation specifications see Installation Instructions

Note

- The overview of profile allocation for the individual items is illustrated at the beginning of the chapter 2 "Fittings lists".

EL...	RA.DB...	DB.IF...
EL.A.IF-N.74	RA.DB.A.IF-N.74	DB.IF.74/75/78
EL.A.IF-N.75	RA.DB.A.IF-N.75	DB.IF.74/75/78
EL.A.IF-N.78	RA.DB.A.IF-N.78	DB.IF.74/75/78
EL.A.IF-N.87	RA.DB.A.IF-N.75	DB.IF.74/75/78

Item designation	Item no.	VPA1 Qty./Type	VPA2 Qty./Type	VPA3 Qty./Type
RA.DB.A.IF-N.74.LS	5110281	50 BL	200 KK	1600 EK
RA.DB.A.IF-N.74.RS	5110280	50 BL	200 KK	1600 EK
RA.DB.A.IF-N.75.LS	5110283	50 BL	200 KK	1600 EK
RA.DB.A.IF-N.75.RS	5110282	50 BL	200 KK	1600 EK
RA.DB.A.IF-N.78.LS	5110285	50 BL	200 KK	1600 EK
RA.DB.A.IF-N.78.RS	5110284	50 BL	200 KK	1600 EK

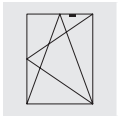
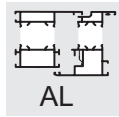
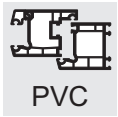

Accessories top rod OS.SE

Anti-Slam Device ZSS OP

- Prevents tilted windows slamming shut in case of light draughts and low window sashes
- For inserting into Top Rod OS.SE
- Can be used left and right hand
- Colour: white

Tilt limiter KBG.OS.SE

- Reduces tilt opening width by approx. 50 mm
 - For inserting into Top Rod OS.SE
 - Can be used left and right hand
-
- Recommendation for use: unfavourable sash formats, e. g.
 - KBG.OS.SE1 for sash rebate heights < 600 mm
 - KBG.OS.SE2 for sash rebate heights < 800 mm

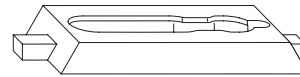

ZSS OP

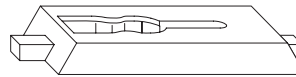

KBG.OS.SE

Item designation	Item no.	VPA1 Qty./Type	VPA2 Qty./Type	VPA3 Qty./Type
ZSS OP WS	2763095	100 BL	1000 KK	8000 EK
KBG.OS.SE.1	4969389	100 BL	1000 KK	8000 EK
KBG.OS.SE.2	4969390	100 BL	1000 KK	8000 EK

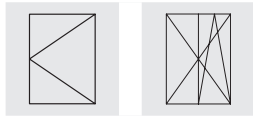
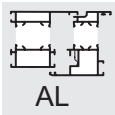

Claw bolt

- Centre lock for turn and double sashes
- Combination of frame component ZV-RT and sash component ZV-FT
- Adjustable for airgaps of 11 to 14 mm
- For left and right hand operation
- Rebate shape see Group 15, installation drawings B-11-...

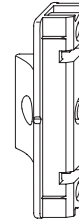

Claw bolt ZV-RT

- Frame part to screw on
- Profile dependent see Group 11, Frame Parts

Claw bolt ZV-FT

- Counter piece for ZV-RT
- Is fixed in the fitting groove hinge side
- Adjustment of contact pressure by means of an Allen key

Item designation	Item no.		Groove centre position	Rebate shape	VPA1 Pcs/type	VPA2 Pcs/type	VPA3 Pcs/type
ZV-FT SL	2359324	2	9/13	10 BL	100 KK	800 EK	

Frame parts

General type descriptions

Designation/short designation/screws

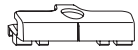

Keep / SBA... / 1

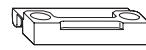

Spacer / FT WSK / 2

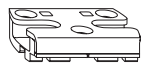

Security keep / SBS... / 3



Claw bolt / ZV ... / 2

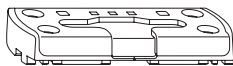

Security keep / SBK... / 4



Sash lifter / FH ... / 2

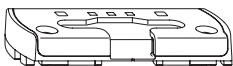

Security tilt keep / SBK... V
Screwed in the prechamber

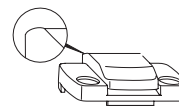

Sash lifter / FH.R. ... / 2 (radius
at rear edge)

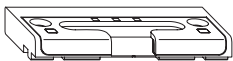

Security tilt keep / SBK... BS / 2
Threshold



Sash lifter / FH.L. ... / 2 (long
version)

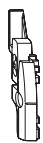

Keep for dual and triple function
element / SBA .. DFE-TFE / 1



Mini vent keep / AS.SBA.K.T / 2

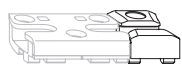

Tilt keep (tilt before turn) /
SBK...E / 1

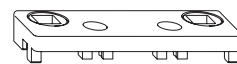

Keep / SA ... / 2



Security keep / SBS.K.PAD (par-
allel action/tilt before turn)

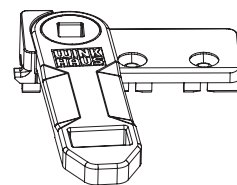

Mini vent keep / AS OF / 2

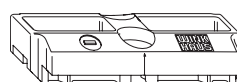



Keep / SA OF / 2

Aliplast

Blyweert

NML 9 mm

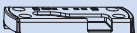
UEB 17 mm







SBK		SBS		SBA		AS SBA, ZV-RT, RT RT.MSL	
SBK.A.75.ZN.KS	4966457	SBS.A.75.WK	4969384	SBA.A.75.KS	4966456	ZV-RT 73RC SL	2808636
SBK.K.E/PAD		BK, FT		FH		SA, SA OF	
SBK WE 12 ACP	4980488	FT WSK 54	1493257				

Aliplast

Ecofutural, Imperial, Superial, Genesis, Star65, Star75, Star90

NML 9 mm

UEB 18 mm







SBK		SBS		SBA		AS SBA, ZV-RT, RT RT.MSL	
SBK.A.75.ZN.KS	4966457	SBS.A.75.WK	4969384	SBA.A.75.KS	4966456	ZV-RT 73RC SL	2808636
SBK.K.E/PAD		BK, FT		FH		SA, SA OF	
SBK WE 12 ACP	4980488	FT WSK 54	1493257			SA SL	1895985

AluK

Venta, Triton

NML 9 mm

UEB 18 mm







SBK		SBS		SBA		AS SBA, ZV-RT, RT RT.MSL	
SBK.A.75.ZN.KS	4966457	SBS.A.75.WK	4969384	SBA.A.75.KS	4966456	ZV-RT 73RC SL	2808636
SBK.K.E/PAD		BK, FT		FH		SA, SA OF	
SBK WE 12 ACP	4980488	FT WSK 54	1493257				

Alumil

11000, 11500, 11600, 20000, 20650, S77

NML 9 mm

UEB 18 mm







SBK		SBS		SBA		AS SBA, ZV-RT, RT RT.MSL	
SBK.A.73.ZN	4965497	SBS.A.73	4984032	SBA.A.73	4965496	ZV-RT 73RC SL	2808636
		SBS.A.73.RC2	5063716				
SBK.K.E/PAD		BK, FT		FH		SA, SA OF	
SBK WE 12 ACP	4980488	BK 73 RC SL	4935920			SA SL	1895985
		FT WSK 54	1493257				

Heroal

W 72

NML 9 mm

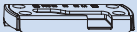
UEB 20 mm







SBK		SBS		SBA		AS SBA, ZV-RT, RT RT.MSL	
SBK.A.78	4926817	SBS.A.78	4969919	SBA.A.78.KS	4936201	ZV-RT.H.9-6-8.AGR	4941344
SBK.A.78.4S	5037184	SBS.A.78.S6	5029921	SBA.A.78.KS.P8	5045792		
SBK.A.78.4S.P8	5045797	SBS.A.78.3S	5037183				
SBK.A.78.V.P8	5045796	SBS.A.78.3S.P5	5094562				
		SBS.A.78.3S.P8	5045794				
		SBS.A.78.P8	5045793				
		SBS.A.78.S6.P8	5045795				
SBK.K.E/PAD		BK, FT		FH		SA, SA OF	
SBK WE 12 ACP	4980488	BK SL	1793250	FH.78	5093683	SA SL	1895985
		FT WSK 78	1992232				

Reynaers

CS77 (9NML)



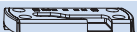



NML 9 mm

UEB 20 mm

SBK		SBS		SBA		AS SBA, ZV-RT, RT RT.MSL	
SBK.A.73.ZN	4965497	SBS.A.73.RC2	5063716	SBA.A.73	4965496	ZV-RT 73RC SL	2808636
SBK.A.74	4990443	SBS.A.74	4990444	SBA.A.74	4990442		
SBK.K.E/PAD		BK, FT		FH		SA, SA OF	
SBK WE 12 ACP	4980488	BK 73 RC SL	4935920			SA SL	1895985
		FT WSK 54	1493257				

Sapa
Avantis 70

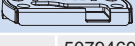
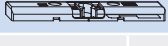
NML 13 mm
UEB 18 mm

SBK 	SBS 	SBA 	AS SBA, ZV-RT, RT RT.MSL 
SBK.A.87.ZN 5059268	SBS.A.87.ZN.RC 5059281	SBA.A.87 5059267	
SBK.K.E/PAD 	BK, FT 	FH 	SA, SA OF
SBK.A.87.KVD 5079469			

Notes on these assembly instructions

Prerequisites:

The mounting instructions are designed for mounting Winkhaus activPilot fittings for windows and glazed doors only. Fittings are designed for the following sash rebate sizes and sash weights:

- Min. sash rebate width 380 mm
- Max. sash rebate width 1725 mm
- From 1475 mm sash rebate width with additional shear ZSR
- Min. sash rebate height 230 mm
- Max. sash rebate height 2800 mm
- Max. sash size 3 m²
- Max. sash weight 130 kg
- Ratio between sash rebate width: sash rebate height \leq 2:1
- Airgap, horizontal 12 +1 mm



Note: In order to ascertain the permissible sash sizes and sash weights, please refer to the diagrams in the chapter "General Product Information".

Observe instructions on window profile

You must specifically take into account information provided by the profile manufacturer or system owner when determining the maximum sash sizes and sash weights!

13

Persons involved in mounting fittings must have read and understood this fitting guide. Observe production liability information for all work with fittings. Manufacturer will accept no liability in cases of failure to comply with this guide, deployment of insufficiently qualified staff and unauthorised alterations.

The respective overall fitting must be selected from the original fitting components range. Winkhaus accepts no liability if non-original or unauthorised system accessory parts are used.

Profile design - Aluminium windows

See figure: Profile cross-section

The fitting system is suitable for all aluminium windows with standard fitting groove and designed for an airgap of 12 mm and overlaps of 18 to 24 mm.

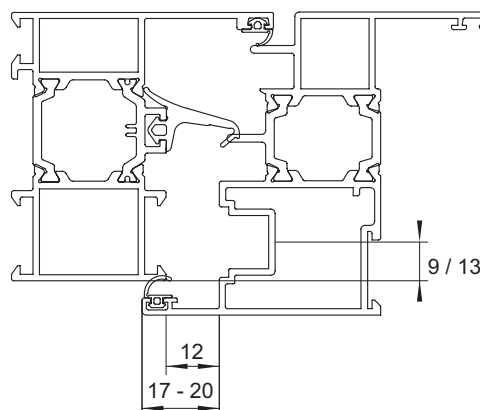

Profile cross-section



Important: The screw / clamping connection of load-bearing fitting components, such as corner, shear and sash hinges must be designed according to the TBDK guidelines. Please adapt the fixing procedure of the fitting components to the load situation.



Important: Frame and sash components in water-bearing profile levels must be screwed in a way to avoid water entering into profile levels that cannot be drained afterwards. Please observe the information given by your system supplier.



Please note! Winkhaus does not provide fastening screws for fitting. Always use fastening screws suitable for the window type and window dimensions.



Important: If clampable components are used, please observe the special information regarding frame parts with bayonet closures.

Shortening the fittings

A detailed description on shortening of fittings is available here. This description will be referred to in these assembly instructions.

See figure: Fittings prior to punching

- Always insert the face plate (1) and drive rod (2) perpendicularly from the top with the face plate (1) pointing to the pressure cylinder.

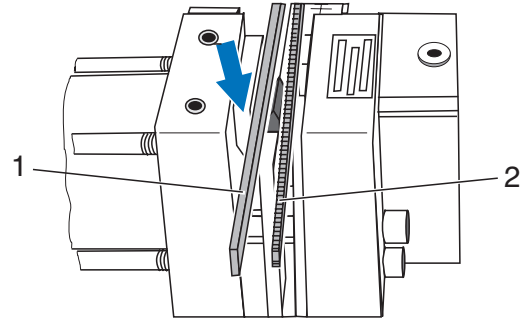

Fittings prior to punching

See figure: Fittings after punching

- After punching, always remove the face plate (1) and drive rod (2) perpendicularly in an upwards direction.

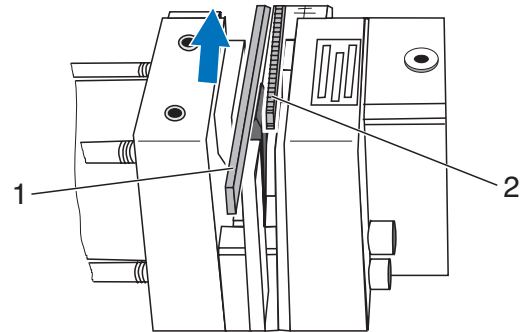

Fittings after punching

13

See figure: Cleaning the supporting surfaces

- Keep the supporting surfaces (3 and 4) clean.

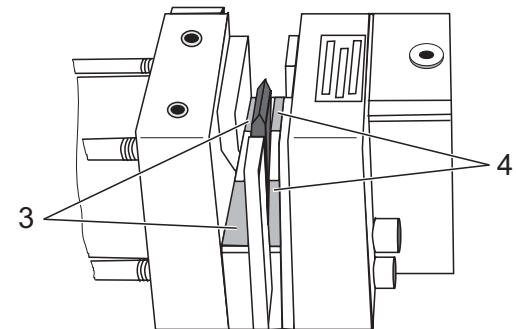

Cleaning the supporting surfaces

Shorten the drive rod GAM (central handle position)

See figure: Marking GAM

- Set measuring value FFH on the measuring device to the GAM mark.



Please note! If the GAM scale is displaced by one submarking, this corresponds to a longitudinal shift of 2 mm.

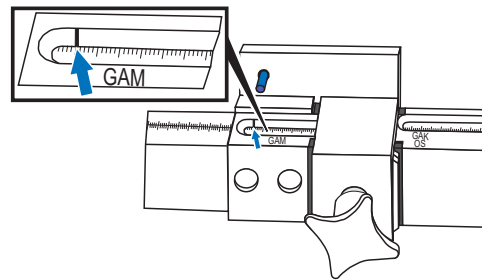

Marking GAM

See figure: Position for shortening drive rod

- Position the GAM drive rod at the scale; slot drill hole (2) onto bolt (1).
- Turn the GAM drive rod around, and slot the drill hole (3) onto the bolt (1), then trim the other side.
- Shorten the drive rod using the fitting punch.

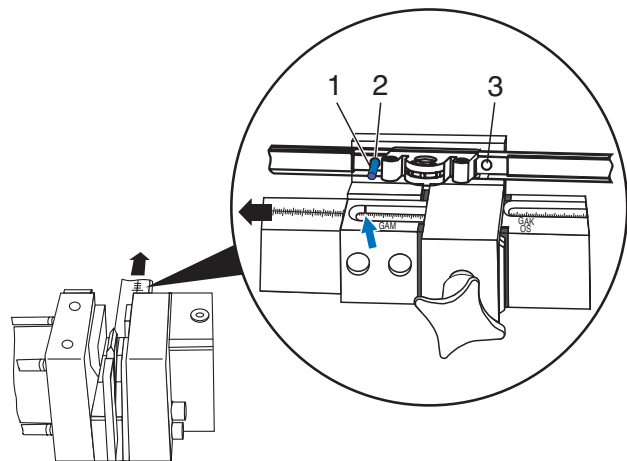

Position for shortening drive rod

Cutting of double sash drive rods GASM

GASM.800

See figure: Cutting instructions GASM

- Adjust the ruler to FFH + 400 mm (example: measured FFH = 567; adjust ruler to 567mm + 400 mm = 967 mm).
- Connect the drive to the marked hole on the ruler (arrows pointing to cutter).
- Cut off the element.

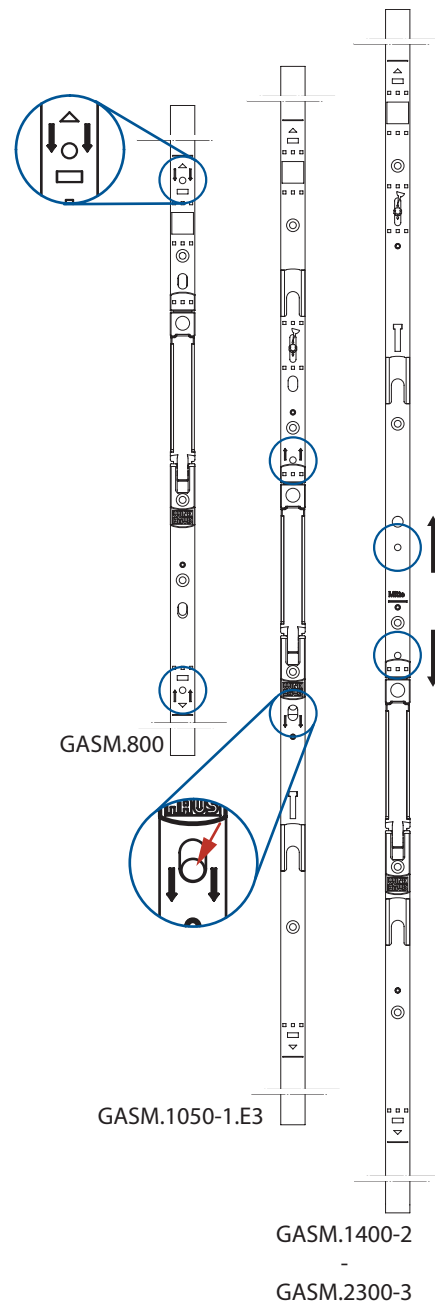

Cutting instructions GASM

GASM.1050 - GASM.2300

See figure: Cutting instructions GASM

- Adjust the ruler to FFH (sash rebate height).
- Connect the drive to the marked hole on the ruler (arrows pointing to cutter).
- In case of GASM.1050 please make sure that the bolt in the elongated hole is positioned as indicated (red arrow).
- Cut off the element.
- GASM.1050 is always used in combination with corner drive E3.



Note: The double-sash drive rod must be trimmed before delivery.

Shorten the GAK / GASK drive rod (constant handle position) and top rod OS



Note: The double-sash drive rod must be trimmed before delivery.

See figure: Markings GAK and OS

- Set the measuring value FFH (GAK/GASK) or FFB (OS) on the measuring device to the GAK/OS mark.



Markings GAK and OS

See figure: Position for shortening drive rod and/or top rod

- Cutting the top rod OS...
 - Position the drive rod GAK/GASK (fixed handle position) (1) or the top rod OS (1) at the bolt (2).
 - Shorten the drive rod (1) or the top rod (1).

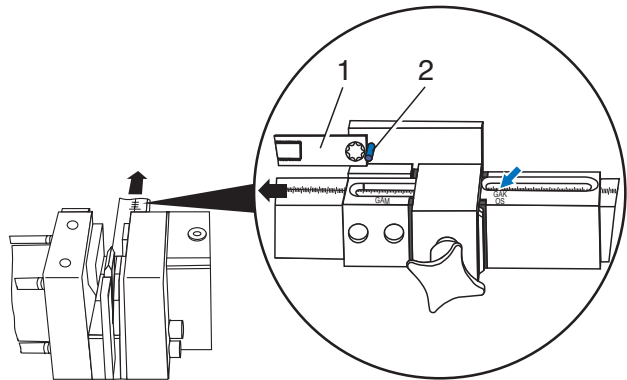

Position for shortening drive rod and/or top rod

Only applies to top rod OS1.600 (OS1.PA.600/OS.XL):

See figure: Position for shortening top rod

- Position the top rod (1) with square holes at bolt (2). At the same time press the offset (see arrow) against the bolt (2).
- Shorten the top rod (1).

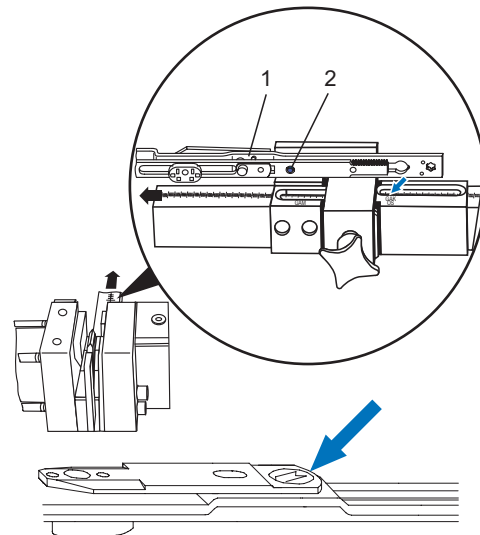

Position for shortening top rod

Mounting of fittings on sash

Utilisation of the clampable “E...N” corner drive with black clamping piece

In case the “E...N” corner hinge (with black clamping piece) is used, please keep in mind that the second (external) screw may only be applied if another component is connected (see illustration below).



If a second screw is fixed to the clamping piece and tightened without joining an additional component, the fitting system might be difficult to operate.

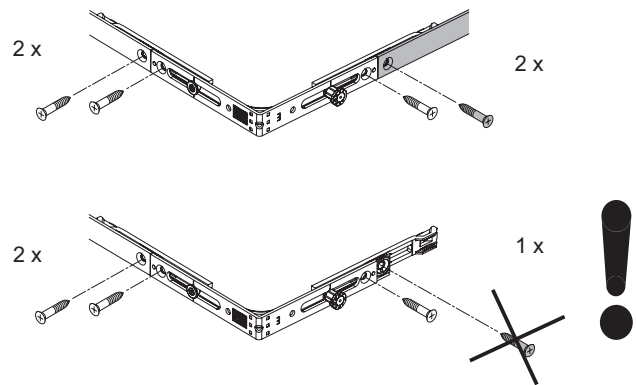

Turn-tilt type - Rectangular window

Prepare the window for fitting. Then proceed as follows:



Note: The following figures refer to a window for right hand use. When fitting a window for left-hand use, the figures will be mirror-inverted.

13

The following also applies:

- When viewing the window from the inside, the symbol is depicted as a full line.
- When viewing the window from the outside, the symbol is depicted as a dotted line.

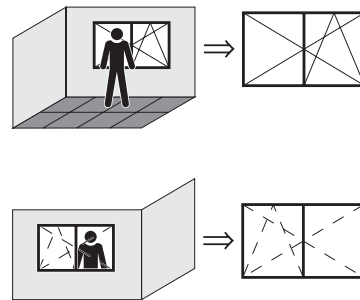

Determine the handle height:

Handle height for drive rod GAM

See figure: Sash rebate height FFH with central handle height GM

If you use a GAM drive rod ... (central handle position), the dimension GM is half the sash rebate height FFH.

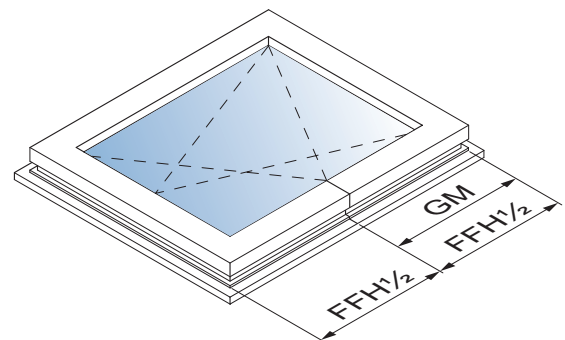

Sash rebate height FFH with central handle height GM

Handle height for drive rod GAK

See figure: Sash rebate height FFH with constant handle position GK

If you use a GAK drive rod ... (constant handle position), dimension GK changes to reflect the sash rebate height FFH. The exact dimensions are specified in the following table.

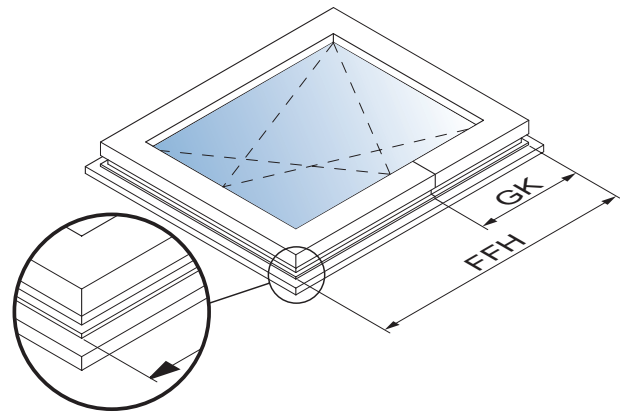

Sash rebate height FFH with constant handle position GK

See figure: Synoptical table: sash rebate height (FFH) / handle position (GK)

The table on the right gives a survey on the handle height (GK) of GAK with regard to the sash rebate height (FFH).

FFH	GK
230 – 324	GK = 114 *
325 – 420	GK = 114 *
421 – 460	GK = 210
461 – 700	GK = 210
701 – 850	GK = 260
851 – 1100	GK = 375
1101 – 1325	GK = 550
1326 – 1525	GK = 550
1526 – 1775	GK = 550
1776 – 2000	GK = 1050
2001 – 2225	GK = 1050

Synoptical table: sash rebate height (FFH) / handle position (GK)
* Requires the use of E3 corner drive

See figure: Scale drawing "Gear lock"

- Drill holes for gear case (ø 12 mm) as per scale drawing. Mill the gear housing from the rebate side:

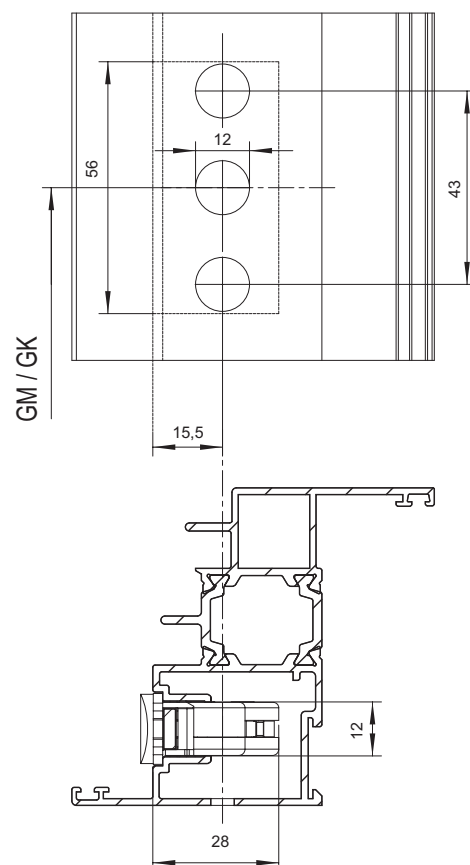

Scale drawing "Gear lock"

Table of gap dimensions for windows that are flush or offset on the inside

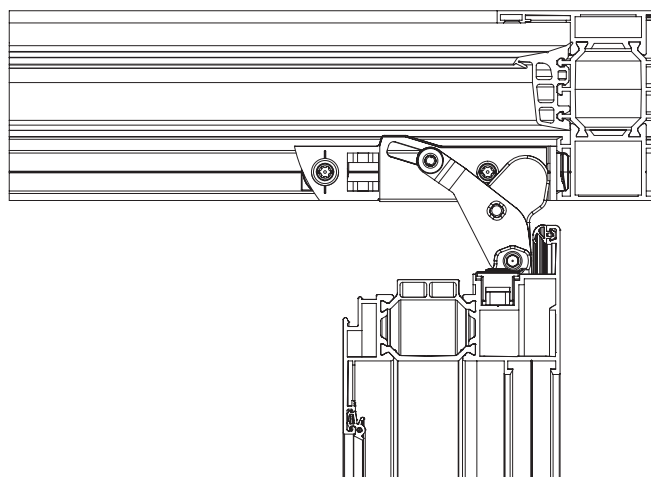
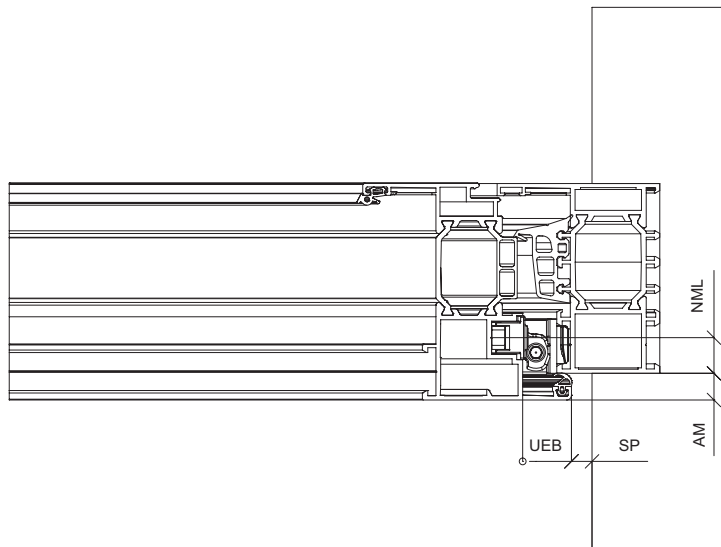

13

AM	UEB	SP 13 mm NML	SP 9 mm NML
10	18	4	5
10	20	4	4

AM = overlap dimension
 UEB = overlap
 NML = groove centre position
 SP = Min. gap dimension
 The gap dimensions also depend on the shape and radiuses of the overlap.

See figure: Corner drive E1

- Mounting of interlocking rods:
 - Fit the corner drive (2) into the fitting groove at the top of the sash so that the octagonal bolt is on the top side.
 - Fit the corner drive (1) into the fitting groove at the bottom of the sash so that the octagonal bolt is on the underside.
 - Fix both corner drives (1, 2) on the drive side with a single screw each.
 - Measure the sash rebate height (FFH).

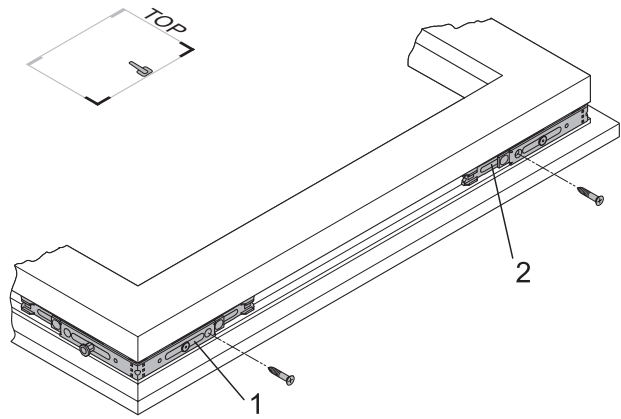

Corner drive E1

See figure: Drive rod GAM/GAK

- Cut the drive rod according to the instructions.
- Mount the drive rod:
 - Abut the drive rod (2) flush against the corner drive (3).
 - Allow the teeth on the drive rod to click into position on the gear rack on the corner drive.
 - Clip the drive rod into the corner drive (1) in the same way.
 - Press the drive rod into the eurogroove.
 - Screw the drive rod from the bottom up.

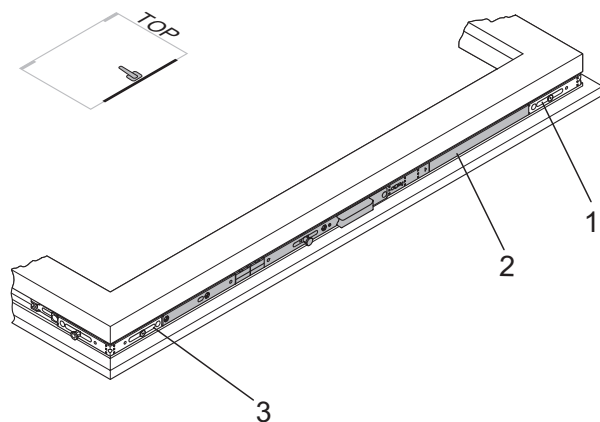

Drive rod GAM/GAK



Note: Please make sure that the installation position of the drive rod is correct!

See figure: Corner Drive E1.SE

- Fit the corner drive (1) into the fitting groove at the top of the sash so that the octagonal bolt is on the hinge side.
- Fasten the corner drive on the sash using a screw (2).
- Measure the sash rebate width (FFB).

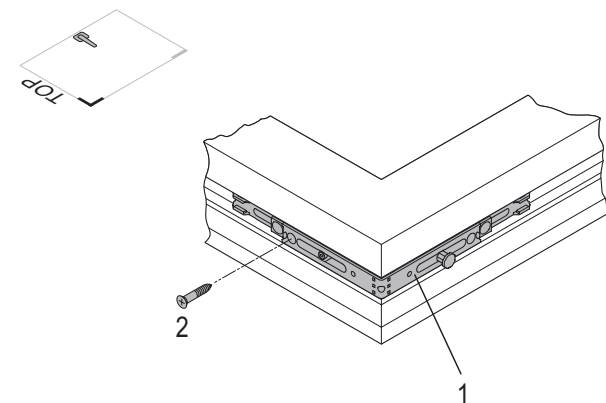

Corner Drive E1.SE

See figure: Top Rod OS.SE

- Insert the top rod and screw into position.
 - Fit the top rod flush against the corner drive (1).
 - Allow the gear teeth to click into place on the rack in the corner drive.
 - Clip the top rod into the corner drive (3) in the same way.
 - Press the top rod into the fitting groove.
 - Screw the top rod from the hinge side to the drive side.



Note: For FFH < approx. 600 mm (depending on profile), place tilt limiter on top rod OS... (2).

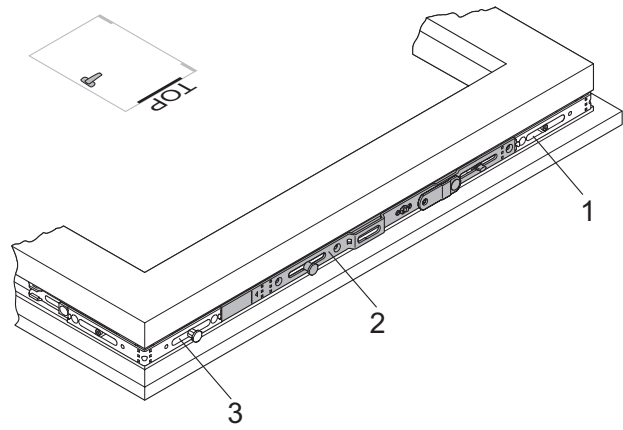

Top Rod OS.SE

See figure: Interlocking rod M/MK (hinge side)

- Install Interlocking Rod on the hinge side.
 - Fit the interlocking rod (1) flush against the corner drive (2).
 - Click the interlocking rod gears into the teeth of the corner drive.
 - Press the interlocking rod into the fitting groove.
 - Screw the interlocking rod from the top down.
 - Tighten the screw (3) fully to release the central fastening.

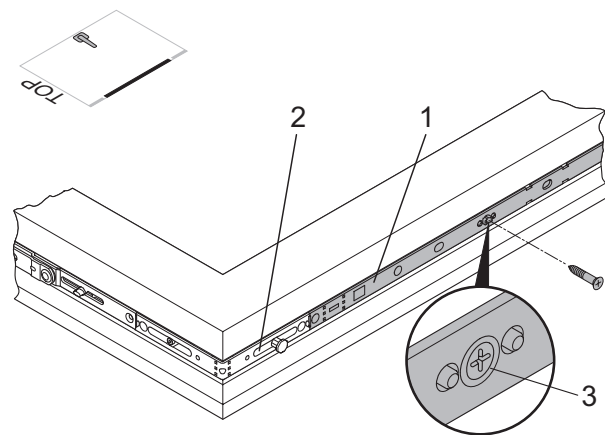

Interlocking rod M/MK (hinge side)



Note: For a sash rebate height (FFH) and/or sash rebate width (FFB) of approx 800 mm (depending on the profile) an interlocking rod should also be fitted hinge-side and/or horizontally at the bottom / top.



Please note! Damage to fittings. If the central fastening is not released, the locking device cannot be actuated. Use of force will lead to torsion of the fittings. Always insert the screw fully up to the stop.

See figure: Corner drive E1

- Screw the corner drive (1) in place.

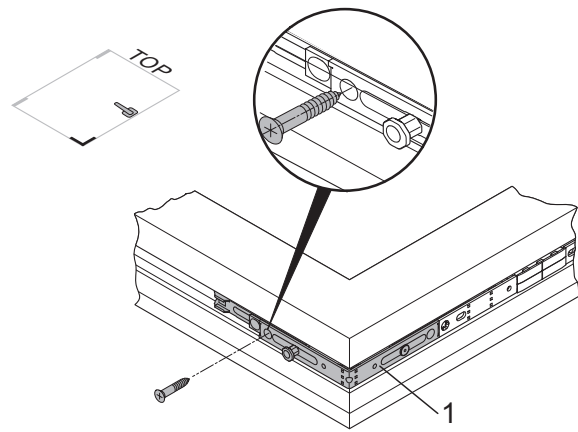

Corner drive E1



Note: the following step is not needed, if you do not fit centre locking to the top corner drive.

See figure: Interlocking rod M/MK (horizontal)

- Mount interlocking rod on the underside:
 - Abut the interlocking rod (2) flush against the corner drive (1).
 - Click the interlocking rod gears into the teeth of the corner drive.
 - Press the interlocking rod into the fitting groove.
 - Screw the interlocking rod from the corner drive to the centre of the window.
 - Tighten the screw (3) fully to release the central fastening.



Please note! Damage to fittings. If the central fastening is not released, the locking device cannot be actuated. Use of force will lead to torsion of the fittings. Always insert the screw fully up to the stop.

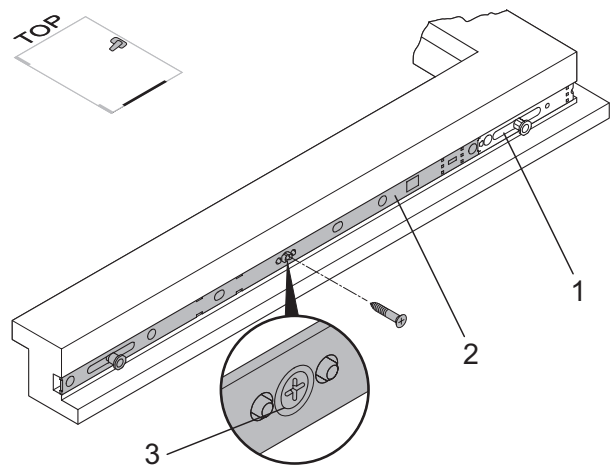

Interlocking rod M/MK (horizontal)

See figure: Sash Hinge FL.IF

- Fitting the sash hinge:
 - Insert sash hinge (1) into the fitting groove on the bottom of the sash.
 - Make sure the sash hinge is fitted correctly into position.
 - Screw the sash hinge (1) in place (start at hinge side).



Note: If a turn limiter is to be connected to the sash hinge, the screw hole (2) must be exposed first.

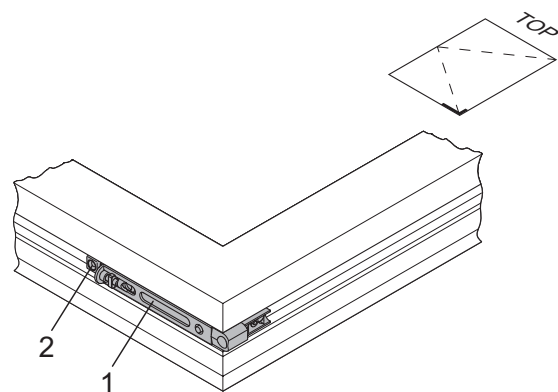

Sash Hinge FL.IF

See figure: Turn Limiter DB.IF

- Install turn limiter
 - Insert the turn limiter (2) into the fitting groove and connect to the sash hinge (1).
 - Fasten the turn limiter (2) tightly to the sash hinge (1) with a screw.
 - Push the shear arm down so that the screw holes underneath are exposed.
 - Screw turn limiter (2) into place.



Note: The holder (3) must point downwards with the guide edge facing the sash overlap.

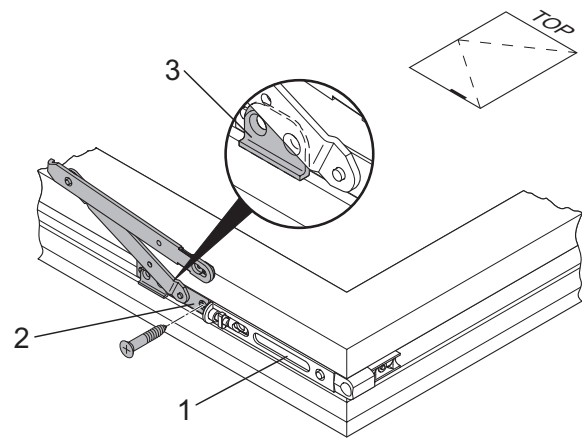

Turn Limiter DB.IF

Using the turn limiter is imperative if:

- Reveal depth of surrounding masonry < 120 mm (DIN EN 13126-8, Point 4)



Note: A turn limiter should optionally be used on elements that are used as a doorway.



Please note! Check if all screws are fixed into place on the fitting parts.

Mounting of fittings on sash

Turn double sash type – Rectangular window

i Note: The following figures refer to a window for left hand use. When fitting a window for right-hand use, the figures will be mirror-inverted.

See figure: Corner drive E1

- Mounting of interlocking rods:
 - Fit the corner drive (2) into the fitting groove at the top of the sash so that the octagonal bolt is on the top side.
 - Fit the corner drive (1) into the fitting groove at the bottom of the sash so that the octagonal bolt is on the underside.
 - Fix both corner drives (1, 2) on the drive side with a single screw each.
 - Measure the sash rebate height (FFH).

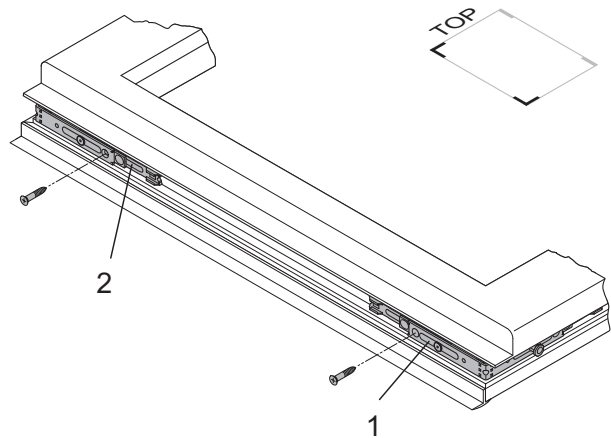

Corner drives E1

- Shorten the drive rod:
 - Shorten drive rod GASM or drive rod GASK in line with description "Shortening the fittings".

i Note: Make sure you shorten the drive rod in closed state (as delivered).

See figure: Drive rod GASM/GASK

- Mount the drive rod:
 - Abut the drive rod (2) flush against the corner drive (3).
 - Allow the teeth on the drive rod to click into position on the gear rack on the corner drive.
 - Clip the drive rod into the corner drive (1) in the same way.
 - Press the drive rod into the eurogroove.
 - Screw the drive rod from the bottom up.

i Note: to keep a neutral position, do not perform a function test until all fittings are in place.

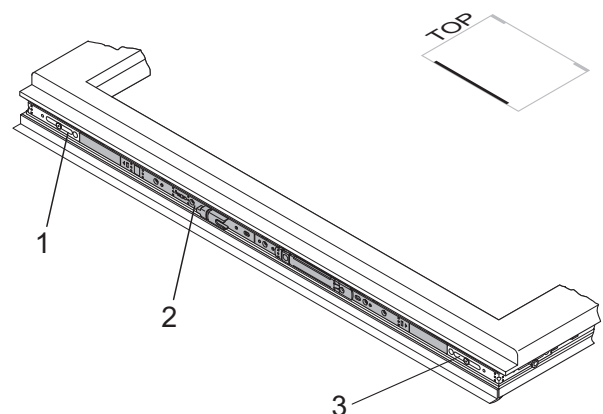

Drive rod GASM/GASK

See figure: Turn hinge rail DLS.IF

- Install turn hinge rail:
- Insert Top hinge rail (1) into the fitting groove on the top of the sash.
- Make sure the turn hinge rail is fitted correctly into position on hinge side.
- Screw top hinge rail tightly onto the sash.

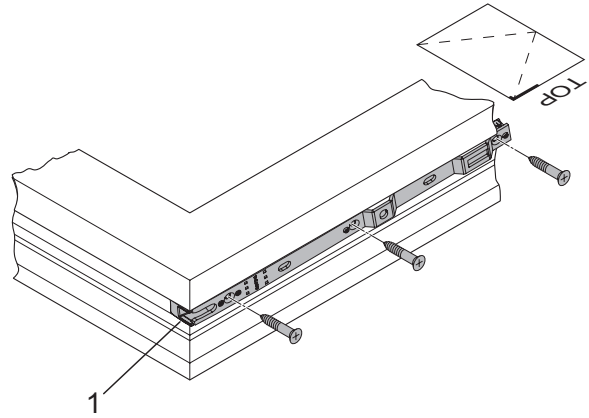

Turn hinge rail DLS.IF

See figure: Interlocking rod M (top)

- Mount the interlocking rod on the top side:
- Fit the interlocking rod (1) flush against the corner drive (2).
- Click the interlocking rod gears into the teeth of the corner drive.
- Press the interlocking rod into the fitting groove.
- Screw the interlocking rod tight from the hinge side to the gear side.
- Tighten the screw (3) fully to release the central fastening.

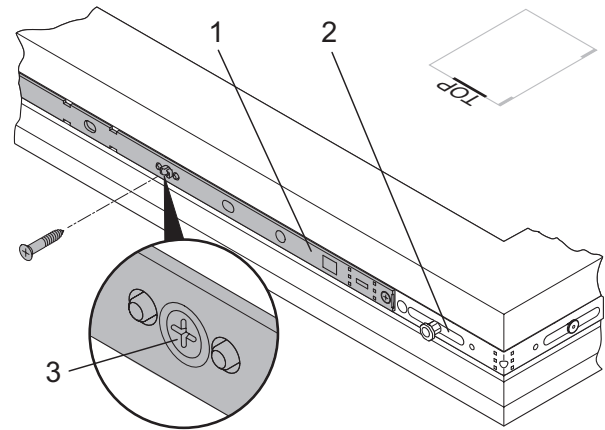

Interlocking rod M (top)



Please note! Damage to fittings. If the central fastening is not released, the locking device cannot be actuated. Use of force will lead to torsion of the fittings. Always insert the screw fully up to the stop.

13

See figure: Interlocking rod M (bottom)

- Mount interlocking rod on the underside:
- See above

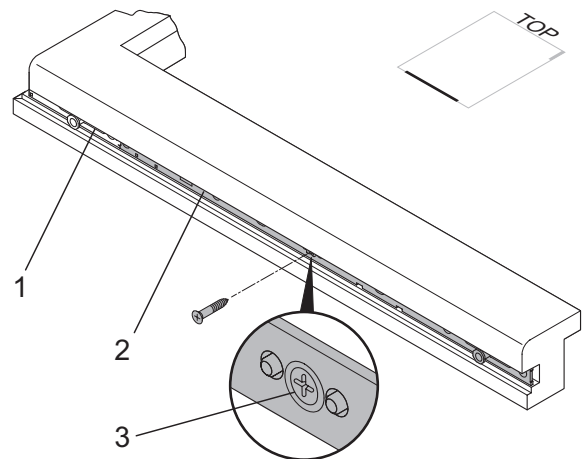

Interlocking rod M (bottom)

See figure: Claw bolt ZV-FT (hinge side)

- Position the claw bolt (1):
- S (ZV-FT) = sash rebate edge to centre of keep ZV-FT
- Press the claw bolt into the eurogroove and screw in place.

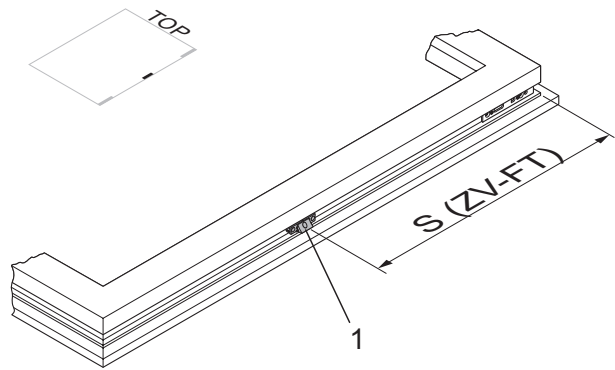

Claw bolt ZV-FT (hinge side)

See figure: Sash Hinge FL.IF

- Fitting the sash hinge:
- Insert sash hinge (1) into the fitting groove on the bottom of the sash.
- Make sure the sash hinge is fitted correctly into position.
- Screw the sash hinge (1) in place (start at hinge side).



Note: If a turn limiter is to be connected to the sash hinge, the screw hole (2) must be exposed first.

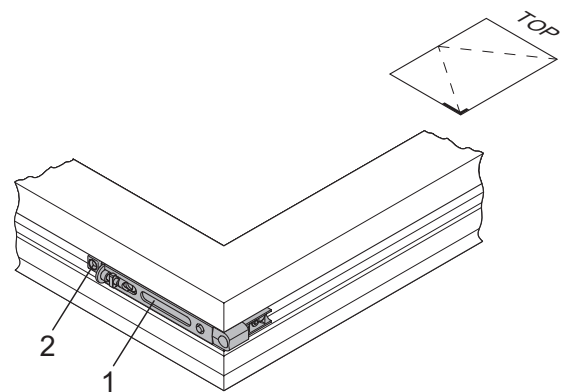

Sash Hinge FL.IF

See figure: Turn Limiter DB.IF

- Install turn limiter
- Insert the turn limiter (2) into the fitting groove and connect to the sash hinge (1).
- Fasten the turn limiter (2) tightly to the sash hinge (1) with a screw.
- Push the shear arm down so that the screw holes underneath are exposed.
- Screw turn limiter (2) into place.



Note: The holder (3) must point downwards with the guide edge facing the sash overlap.

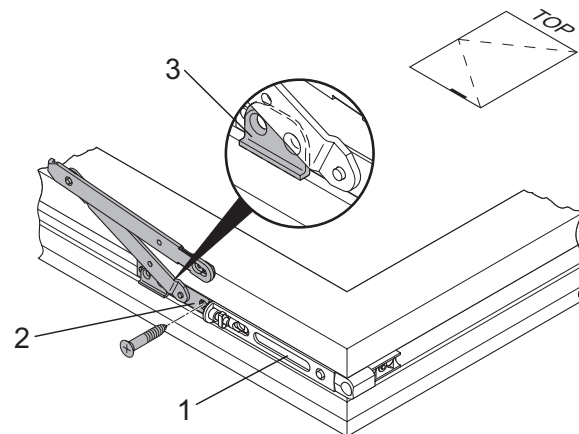

Turn Limiter DB.IF

Using the turn limiter is imperative if:

- Reveal depth of surrounding masonry < 120 mm (DIN EN 13126-8, Point 4)



Note: A turn limiter should optionally be used on elements that are used as a doorway.

Mounting of fittings on the window frame

Type: rectangular turn-tilt window

Keep positions

The following figures show the keep position options. The number of keeps depends on the size of the window.

It is only possible to use frame parts which are suitable for the profile systems concerned and which have been approved by Winkhaus. The use of frame parts not developed especially for the frame profile concerned is not permitted and excludes us from any liability.



Note: The dimensions in the illustrations refer to the length from the frame rebate edge to the keep profile edge! A quick and simple assembly is made possible with the help of mounting jigs.

Turn-tilt window GAK

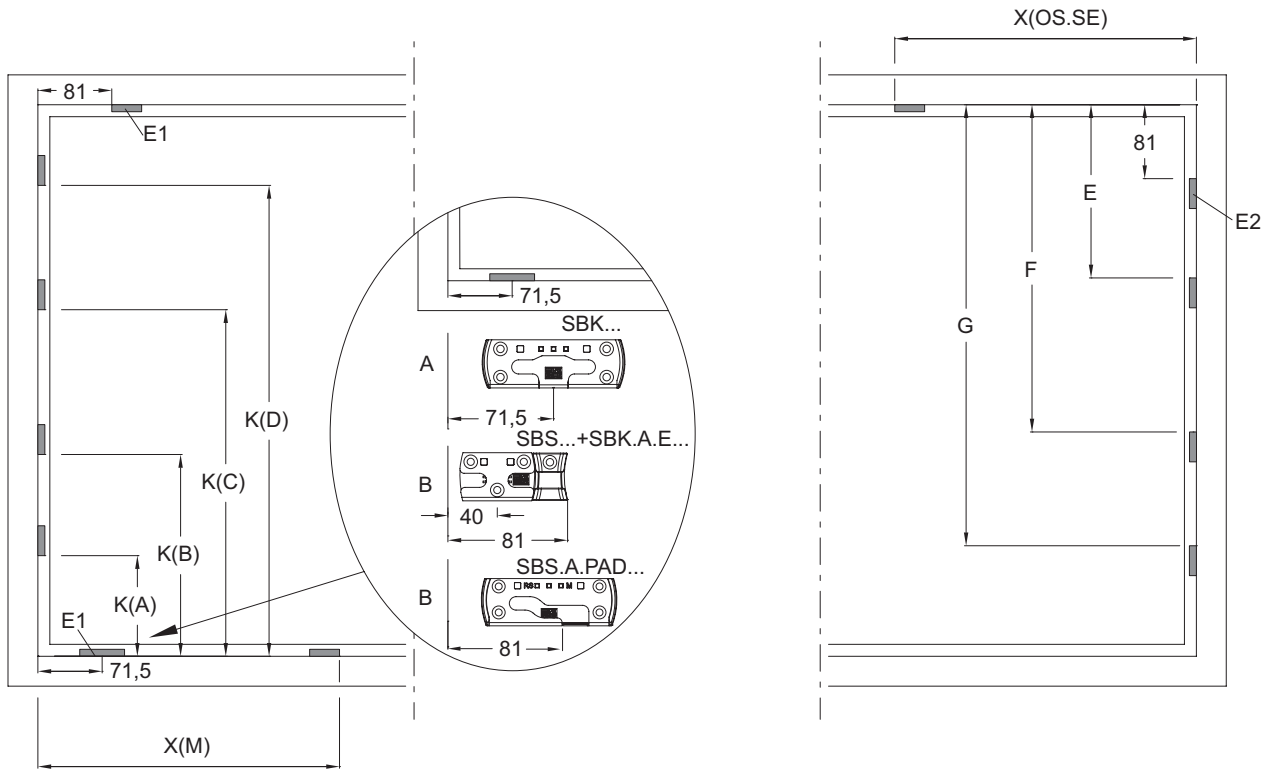

GAK...	K(A) [mm]	K(B) [mm]	K(C) [mm]	K(D) [mm]
GAK.830-1	385	-	-	-
GAK.945-1	385	-	-	-
GAK.1100-1	500	-	-	-
GAK.1195-1	750	-	-	-
GAK.1195-2	250	750	-	-
GAK.1325-1	750	-	-	-
GAK.1325-2	385	750	-	-
GAK.1550-1	750	-	-	-
GAK.1550-2	385	1000	-	-
GAK.1775-2	750	1250	-	-
GAK.1775-3	385	750	1250	-
GAK.2000-2	750	1250	-	-
GAK.2000-4	385	750	1250	1500

M...	X(M) [mm]
M.250-1	230
M.500-1	480
M.750-1	730

OS.SE...	X(OS) [mm]
OS.SE.1025-1 / OS.SE.1025-1.E	480
OS.SE.1250-1 / OS.SE.1250-1.E	480

M...	E [mm]	F [mm]	G [mm]
M.250-1	250	-	-
M.500-1	500	-	-
M.750-1	750	-	-
MK.250-1 + M.250-1	250	500	-
MK.500-1 + M.500-1	500	1000	-
MK.750-1 + M.500-1	750	1250	-
MK.750-1 + M.750-1	750	1500	-
MB.1000-2	500	1000	-
MB.1250-2	750	1250	-
MB.1450-2	750	1450	-
MB.1750-3	750	1250	1750

The illustration GAM.../GAK... shows the keep positions for backsets D15.5, D7.5 and D25-50. These positions also apply to GAMA/GAKA drive rods.
 A = Standard operating sequence turn-tilt (OS.SE...)
 B = Operating sequence Tilt-before-Turn (OS.SE...E)

Turn-tilt window GAM

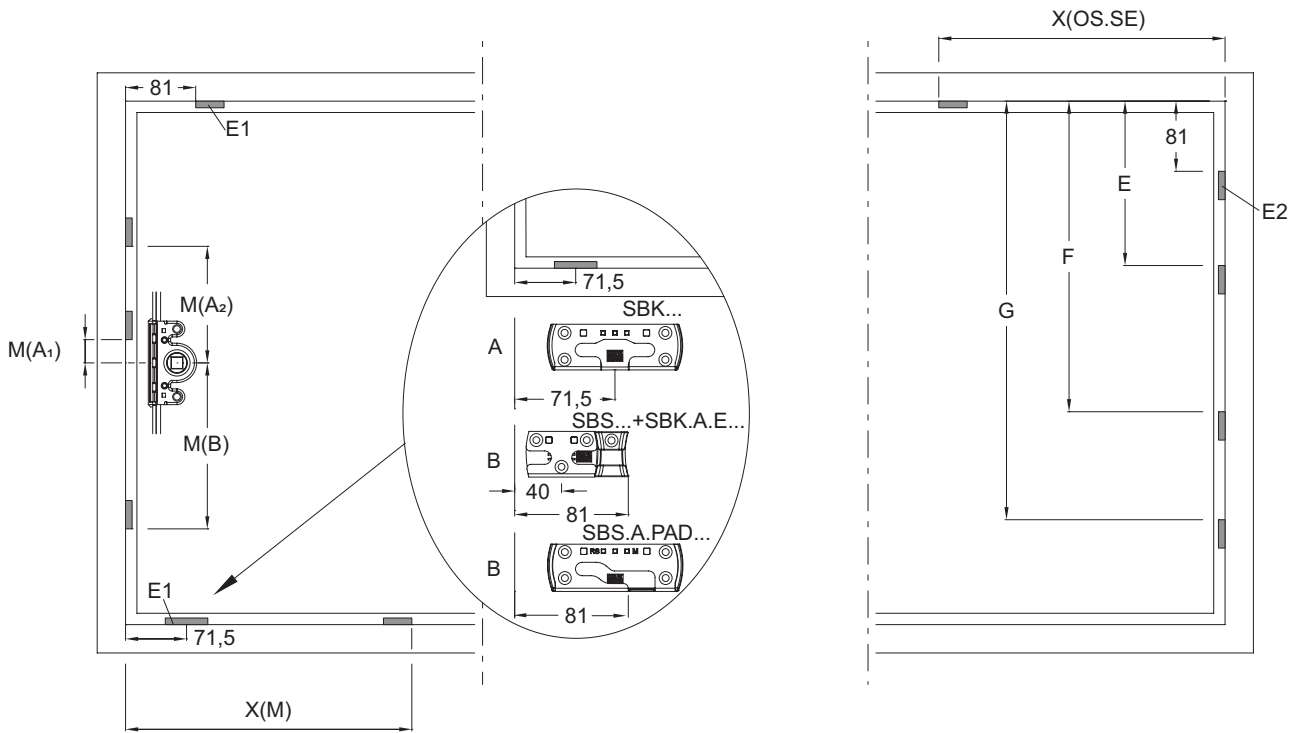

GAM...	M(A ₁) [mm]	M(A ₂) [mm]	M(B) [mm]
GAM.1050-1	127	-	-
GAM.1400-1	127	-	-
GAM.1400-2	127	-	223
GAM.1800-2	-	260	340
GAM.2300-3	127	692	520

M...	X(M) [mm]
M.250-1	230
M.500-1	480
M.750-1	730

OS.SE....	X(OS) [mm]
OS.SE.1025-1 / OS.SE.1025-1.E	480
OS.SE.1250-1 / OS.SE.1250-1.E	480

M...	E [mm]	F [mm]	G [mm]
M.250-1	250	-	-
M.500-1	500	-	-
M.750-1	750	-	-
MK.250-1 + M.250-1	250	500	-
MK.500-1 + M.500-1	500	1000	-
MK.750-1 + M.500-1	750	1250	-
MK.750-1 + M.750-1	750	1500	-
MB.1000-2	500	1000	-
MB.1250-2	750	1250	-
MB.1450-2	750	1450	-
MB.1750-3	750	1250	1750

13

The illustration GAM.../GAK... shows the keep positions for backsets D15.5, D7.5 and D25-50. These positions also apply to GAMA/GAKA drive rods.

A = Standard operating sequence turn-tilt (OS.SE...)

B = Operating sequence Tilt-before-Turn (OS.SE...E)

Double-sash windows turn/turn-tilt

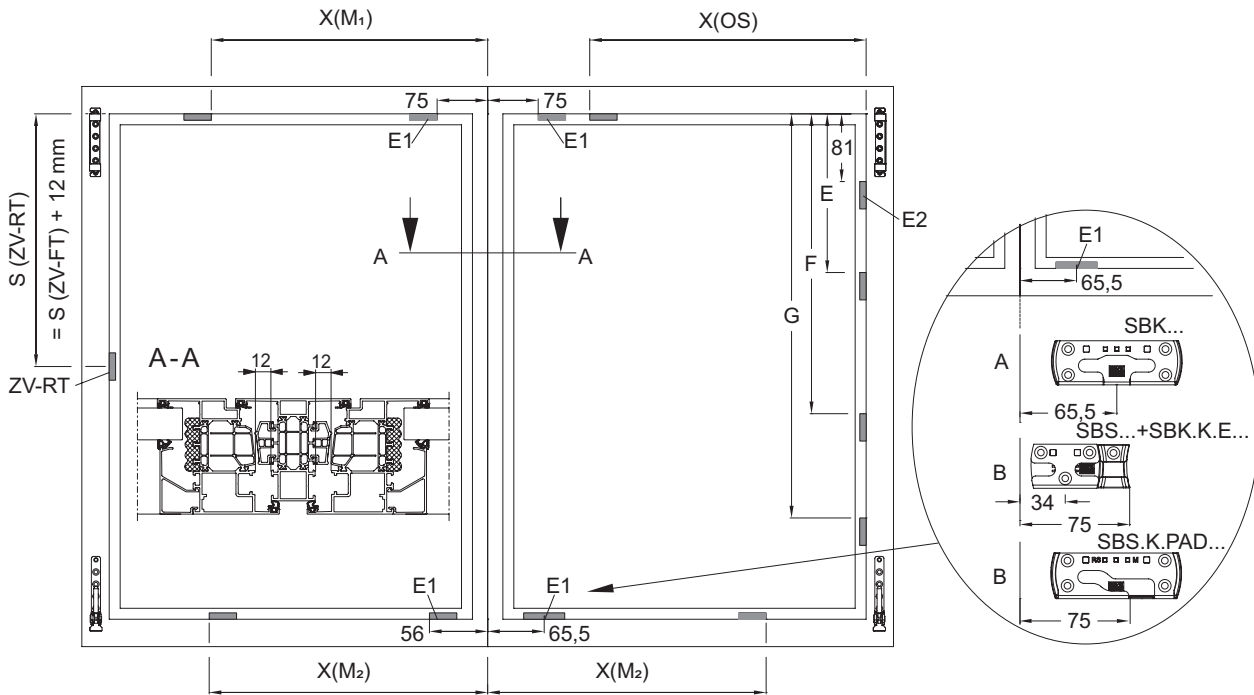

M...	X(M ₁) [mm]
M.250-1	244
M.500-1	494
M.750-1	744

OS2...	X(OS) [mm]
OS2.1025-1 / OS2.1025-1.E	480
OS2.1250-1 / OS2.1250-1.E	730
OS2.1475-1 / OS2.1475-1.E	730

M...	X(M ₂) [mm]
M.250-1	224
M.500-1	474
M.750-1	724

M...	E [mm]	F [mm]	G [mm]
M.250-1	250	-	-
M.500-1	500	-	-
M.750-1	750	-	-
MK.250-1 + M.250-1	250	500	-
MK.500-1 + M.500-1	500	1000	-
MK.750-1 + M.500-1	750	1250	-
MK.750-1 + M.750-1	750	1500	-
MB.1000-2	500	1000	-
MB.1250-2	750	1250	-
MB.1450-2	750	1450	-
MB.1750-3	750	1250	1750

A = Standard operating sequence turn-tilt (OS.SE...)
 B = Operating sequence Tilt-before-Turn (OS.SE...E)
 S (ZV-FT) = sash rebate edge to centre of keep ZV-FT
 S (ZV-RT) = frame rebate edge to centre of claw bolt ZV-FT

Fitting the keeps

Handling of mounting jigs is explained by reference to the L.E.N.K. 710-1100 mounting jig in the following. Other mounting jigs are used in the same way. To position keeps, place the mounting jig on the frame rebate edge.

Labelling of mounting jigs



Horizontal attachment = red element (for top rod and interlocking rod)



Vertical attachment = yellow element (for drive rods and interlocking rods)



Vertical / horizontal attachment = blue element (for corner drives)



= Keep run-in

Keep top horizontal

- Align the mounting jig with the yellow element in the top corner.
- Place the SBA keep on the blue element labelled "E1" and "E2".

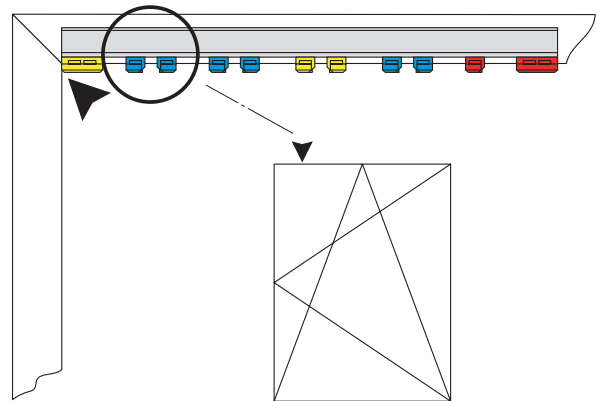

Keep top horizontal

Keep for top rod OS...

- Align the mounting jig with the red element in the top corner.
- Place the keep SBA on the blue element labelled "OS. ...".

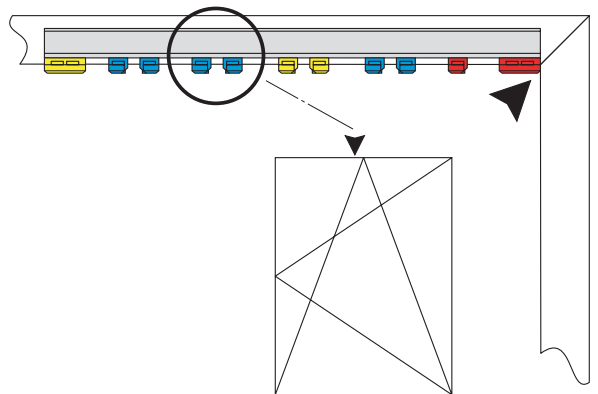

Keep for top rod OS...

Keeps hinge side

- Align the mounting jig with the yellow element in the top corner.
- Position the keep for the corner drive on the blue element.
- Position the keep for interlocking rod on the yellow element.

i Note: The markings on the interlocking rod must match the marking on the yellow element.

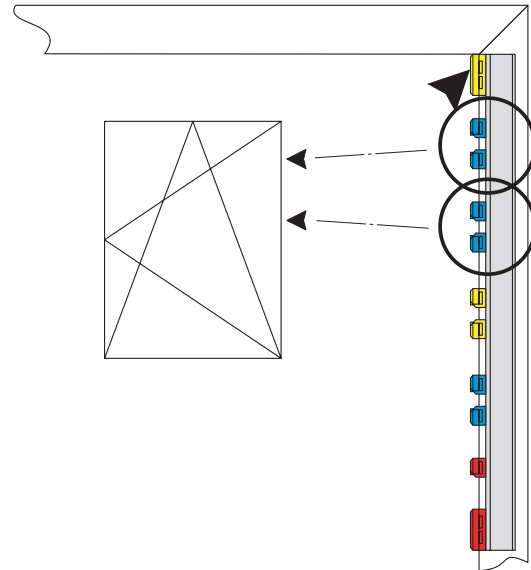

Keeps hinge side

Tilt keep SBK... bottom horizontal

- Align the mounting jig with the red element in the lower corner.
- Place the SBK... keep on the red element marked "Kippblech SBK".

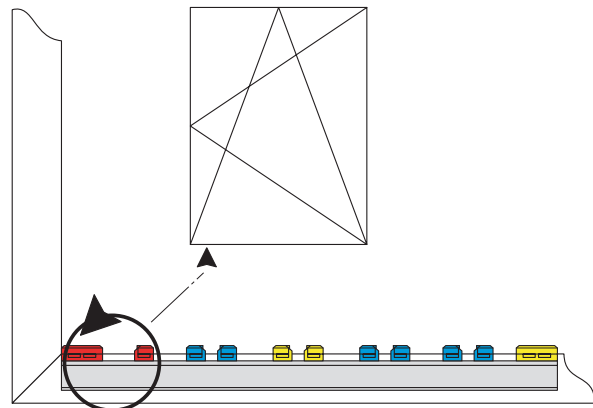

Tilt keep SBK... bottom horizontal

Interlocking Rod M..., bottom, horizontal

See figure: M bottom horizontal

- Align the mounting jig with the red element in the lower corner.
- Position the keep on the blue element marked "M" or "MK".

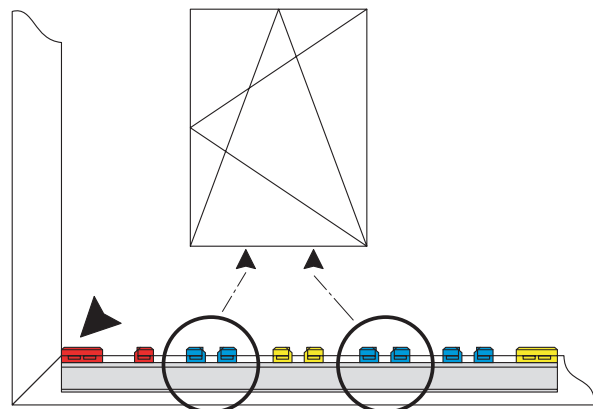

M bottom horizontal

Keeps SBA... for vertical GAK

- Align the mounting jig with the yellow element in the bottom corner.
- Place the SBA. ... keeps on the yellow and blue elements marked "GAK. ...".

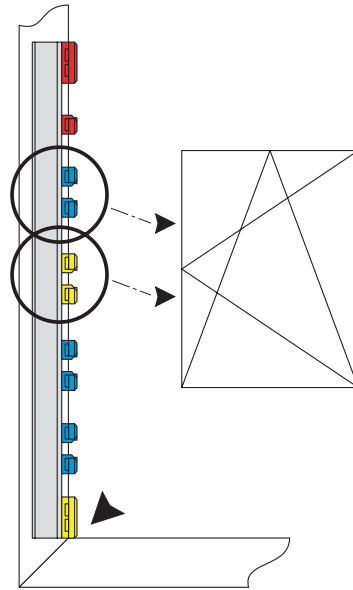

SBA... for vertical GAK

Keeps for GAM

- Attach the corresponding mounting jig labelled "top" or "bottom".
- Fit keeps in line with the labelling on the mounting template.

There are three telescopic jigs depending on the window height:

- LE.N.T. 0710-1050 for drive rod GAM 1050-1
- LE.N.T. 1051-1800 for drive rod GAM 1400-1/2 / 1800-2
- LE.N.T. 1801-2300 for drive rod GAM 2300-3



Note: The labelling on the drive rod must match the labelling on the yellow templates.

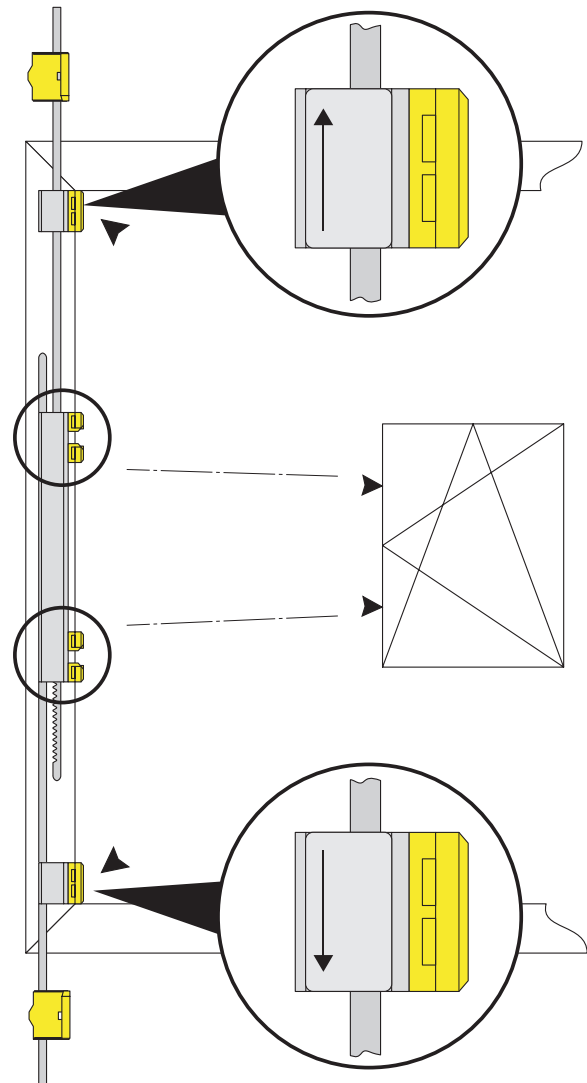

Keeps for GAM

Mounting of fittings on the window frame



It is only possible to use frame parts which are suitable for the profile systems concerned and which have been approved by Winkhaus. The use of frame parts not developed especially for the frame profile concerned is not permitted and excludes us from any liability.

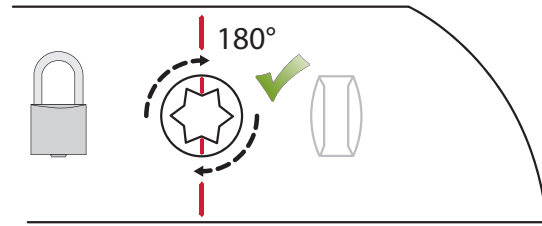

Important if aluminium profiles are used

- For the aluminium version the frame parts adapter plate, corner hinge, shear, turn hinge and frame connection are locked with bayonet closures. The figure shows the right position of the screw (Please observe the marking!).
- The figure shows the two locking positions of the EL.A.SE corner hinge as an example.

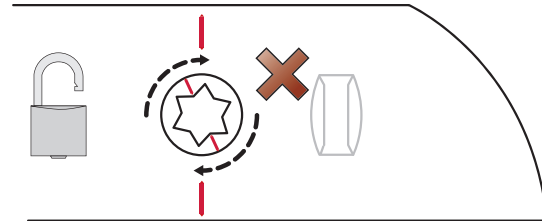

Screw position bayonet closure



Important: It is compulsory to use the correct screw position in order to fix the parts in the aluminium window profile. A false position of the screws might cause the window sash to fall off.



Important: The screw / clamping connection of load-bearing fitting components, such as corner, shear and sash hinges must be designed according to the TBDK guidelines. Please adapt the fixing procedure of the fitting components to the load situation.

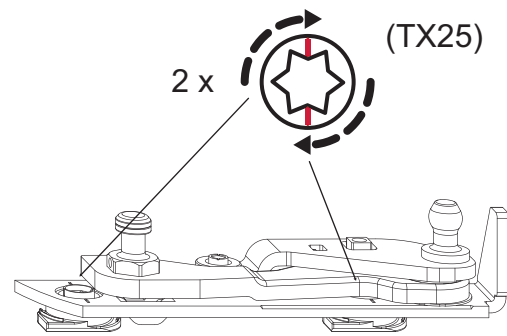

- Mounting the corner hinge

See figure: Mounting the corner hinge

- Tilt the corner hinge slightly to the rear and guide it into the corner parallel to the frame.
- The vertical leg (triangular shape) is threaded into the groove of the keep.
- Tilt the corner hinge forwards (the vertical leg is located in the keep groove and is supported there).

- Push the corner hinge downwards until the bayonet closures are located in the keep groove.
- Make sure the corner hinge is fitted correctly into position.

- Swivel out the support arm so that the bayonet closures are accessible for turning.

- Turn clamping screws (2 pcs.) (see specification).
- Pivot the supporting arms back in.

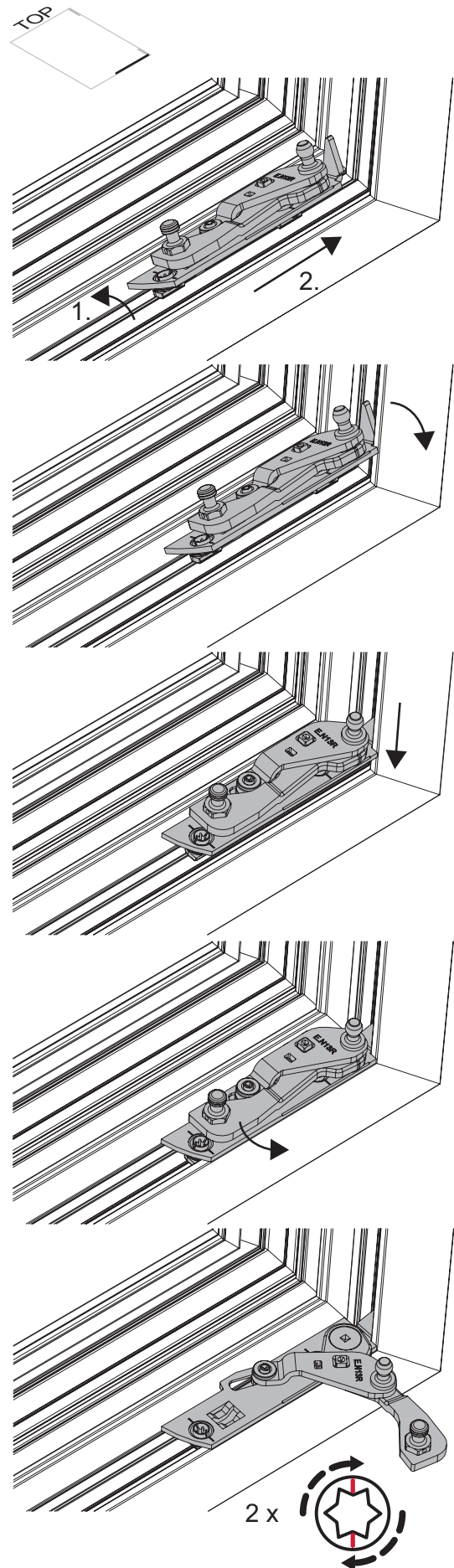

Mounting the corner hinge

- Mounting the shear

See figure: Shear S...IF-N

- Insert the shear (1) into the frame profile (similar to corner hinge).
- Make sure the shear is fitted correctly into position.
- Turn locking screw (see instructions)

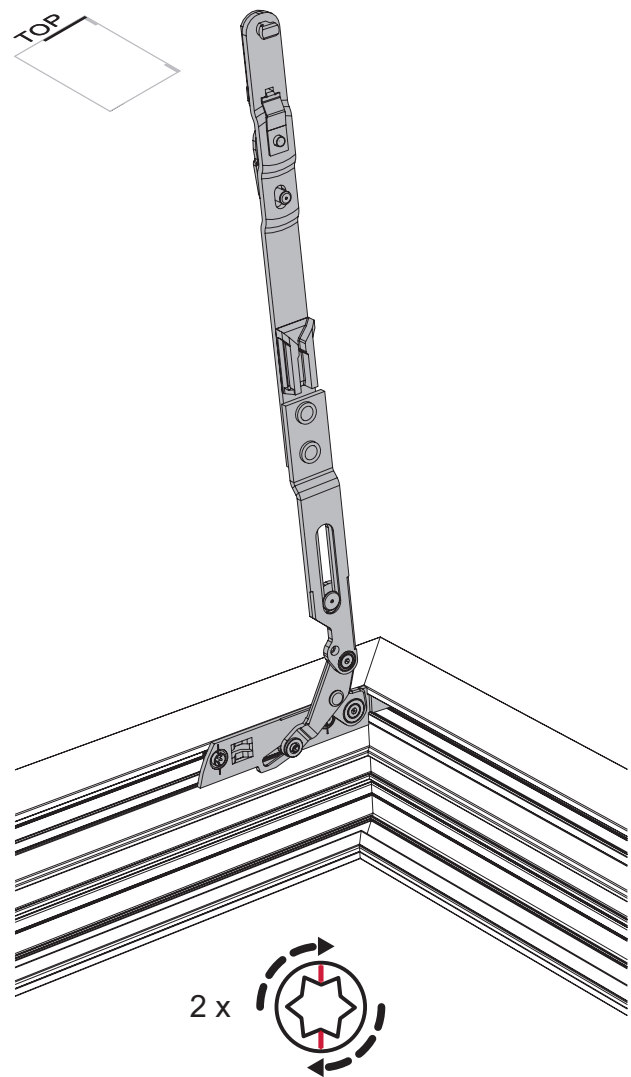

Mounting the shear

- Mount the frame connection

See figure: Frame connection RA.DB...IF

- Insert the frame connection (1) into the frame profile and push against the corner hinge.
- Make sure the frame connection is positively locked.
- Turn locking screw (see instructions)

i Only mount the frame connection if the turn limiter is used.

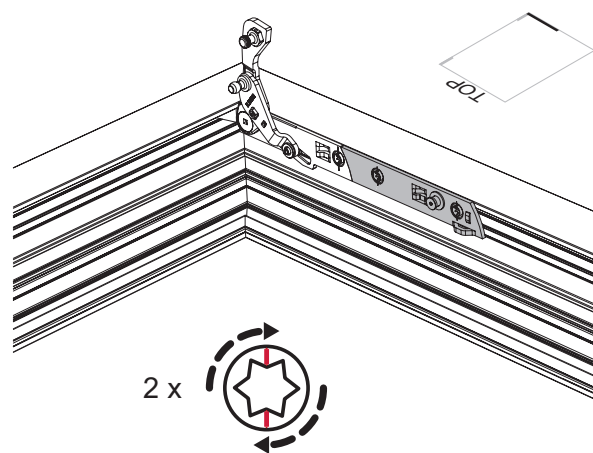

Mount the frame connection

Fitting the sash

Installing sash at the bottom

See figure: Corner and Sash Hinges

- Adjust the fitting to "Turn" position.
- (If there is a fail-safe device, disconnect it.)
- Adjust the corner hinge brackets (1) to the "closed" position.
- Pivot the mount securing device (see figure "Installing the sash at the top"; position 1) 90° outwards and pivot the shear into the frame rebate.
- Lower the sash in a slightly tilted position to the brackets (1).
- Insert bolt (2) in the sash hinge top hinge point while inserting the bolt (3) in the sash hinge groove at the same time.



Important: Secure the window sash against falling. Take the heavy sash weight into account! Two people should carry the sash if necessary.

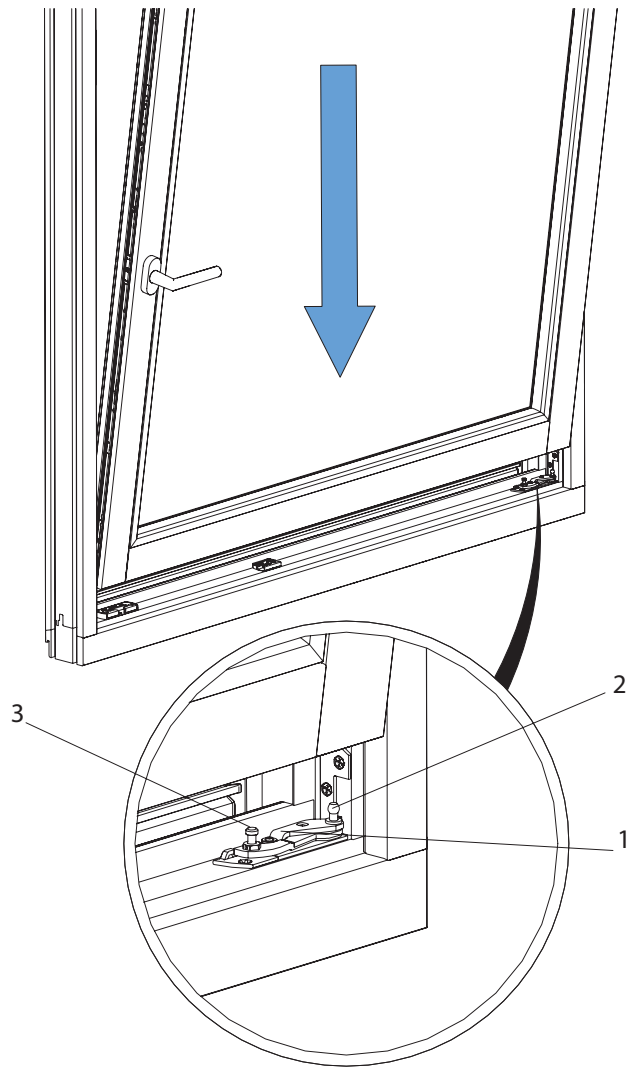

Corner and Sash Hinges



If a turn limiter is used, it must be ensured that it is pivoted inward before the sash is attached. In doing so, damage to the window frame can be avoided!

Support the sash!



Open the sash to a 90° turn position and support!

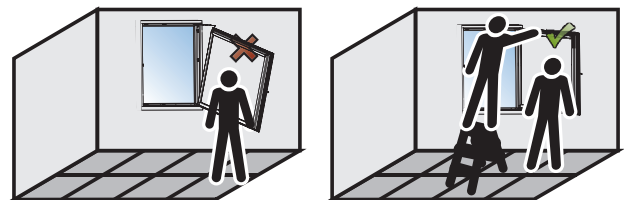

Support the sash!

Engaging the sash at the top

See figure: Engaging the sash at the top

- Open the sash (only surface-mounted on the bottom frame hinge) to a 90° turn position.
- (If there is a fail-safe device, disconnect it.)
- Turn the window handle to the tilt position.
- Open shear 90° and place over the retaining bolt (4) on the top rod.
- Press in the shear bolt (3) into the opening in the counter bracket.
- Press the hammer head bolt into the elongated hole on the top rod. The shear arm should be flush with the top rod.
- Swivel the mount securing device (1) into position by hand, so that the stop spring (2) clicks into place.
- Set fitting to "Turn" position. Then check whether the shear is securely fastened to the top rod and the sash hinge to the corner hinge.



Please note! Risk of injury. The sash can fall out and cause injuries if the shear and top rod are not securely fastened. It is important to ensure the stop spring is firmly in position (clicking sound).



The mount securing device (1) must be pivoted by hand – without the use of tools, such as a hammer, screwdriver, etc. – such that the safety spring (2) detents.

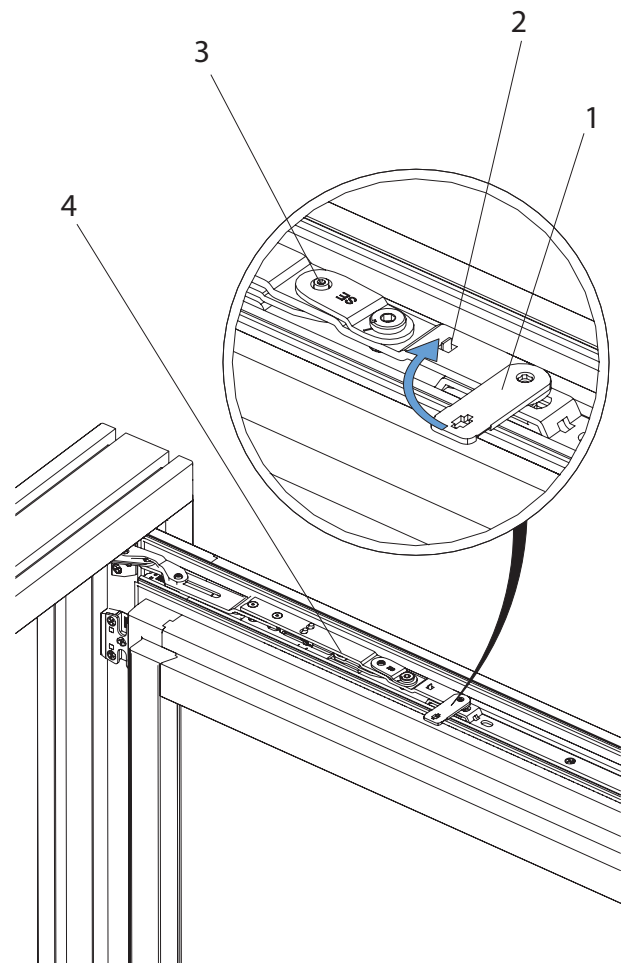

Engaging the sash at the top

Install turn limiter

See figure: Install turn limiter

- Place the turn limiter arm on the retainer pin, so that the stop spring clicks into place behind the retainer pin.
- It is important to ensure the stop spring is firmly in position (clicking sound).

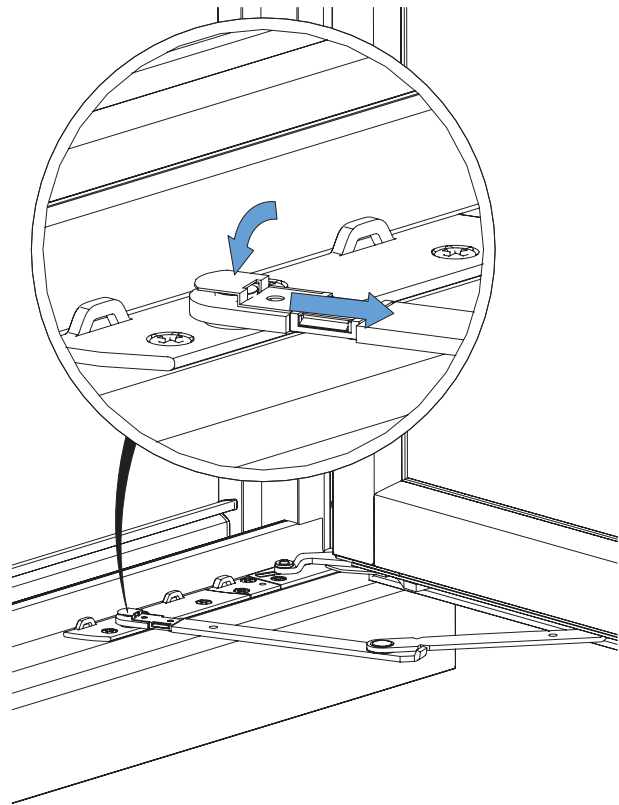

Install turn limiter

Removal of the sash

Detaching the turn limiter

See figure: Detaching the turn limiter

Preparation:

- Move the sash into the 90° turn position.
- Detaching the turn limiter

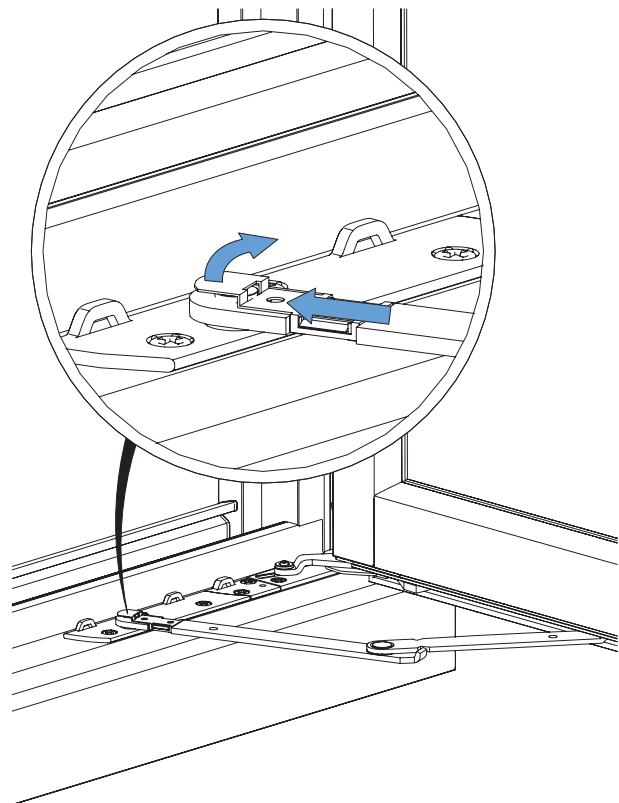

Detaching the turn limiter

Support the sash!

 Open the sash to a 90° turn position and support!

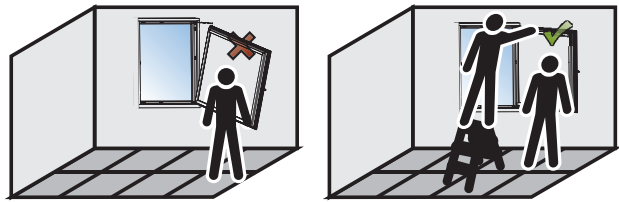

Support the sash!

Unlocking the mount securing device

See figure: Remove the sash

Unlocking the mount securing device (1) of the shear:

- Press down the stop spring (2) with a screwdriver while swivelling the mount securing device (1) outwards 90° at the same time.

 Important: Secure the window sash against falling. Take the heavy sash weight into account! Two people should carry the sash if necessary.

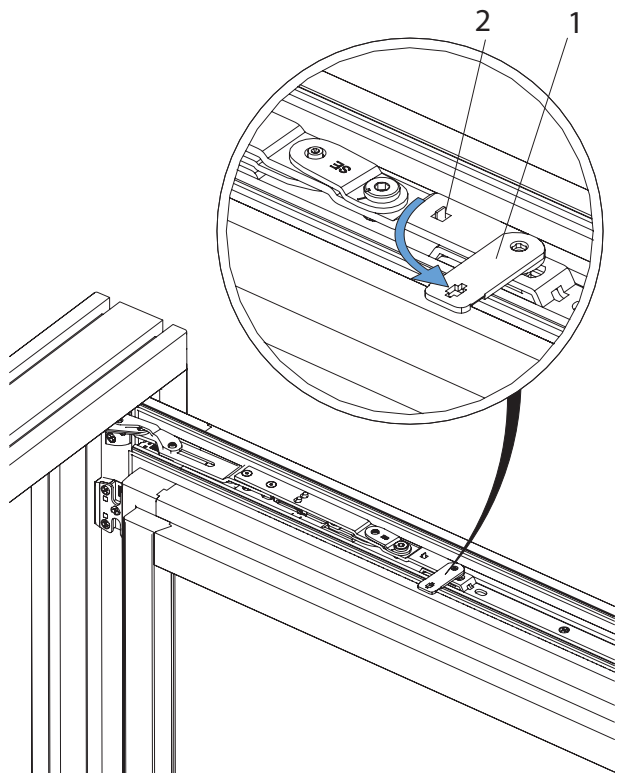

Remove the sash

Lifting the sash out of the bottom frame hinge

See figure: Removing the sash

- Pivot the uncoupled shear arm into the frame rebate.
- Move the sash (only surface-mounted on the bottom frame hinge) to a nearly closed position.
- Tilt the sash slightly and lift it up out of the bottom frame hinge.

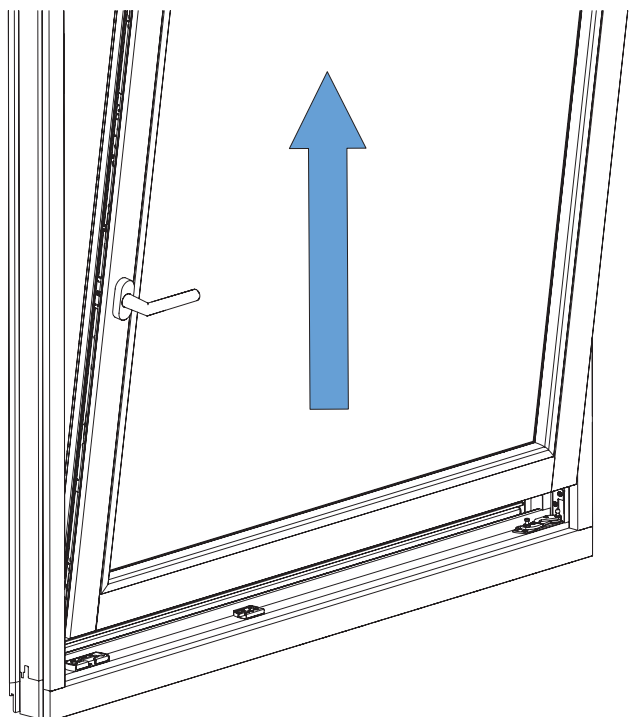

Lifting the sash out of the bottom frame hinge

Function test / Operation

Turn-tilt type

See figure: Function test turn-tilt window

- Place the handle and operate once as follows to release the central fastening.
- Push the handle down (c). The window is closed.
- Move the handle to the central position (a). The window is unlocked; the sash can now be opened fully.
- Close the sash. Push the handle up (b). The window is unlocked; the sash can now be tilted.



Note: The handle will be stiffer than normal the first time it is used. A clicking noise will be heard during actuation. Keep the window closed during actuation.

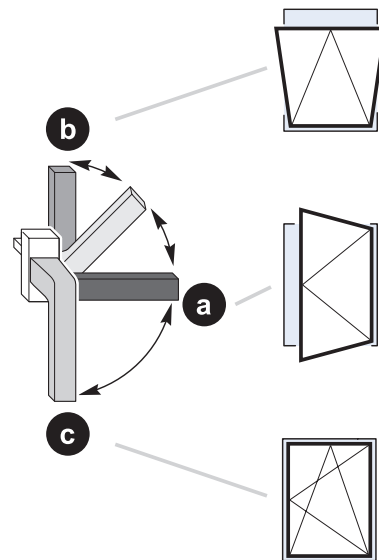

Function test turn-tilt window

Turn double sash type

See figure: Function test turn double sash window

- Actuate the handle as follows to release the central fastening.
- Press the unlocking button (1) and press the lever down to its limit position.
- The window is unlocked; the sash can now be opened fully.



Note: When you actuate the lever for the first time, the gearing is 'unblocked' and coupling to the connected fittings is established. the handle will be stiffer than normal the first time it is used. A cracking noise can be heard when switching. Keep the window closed during actuation.

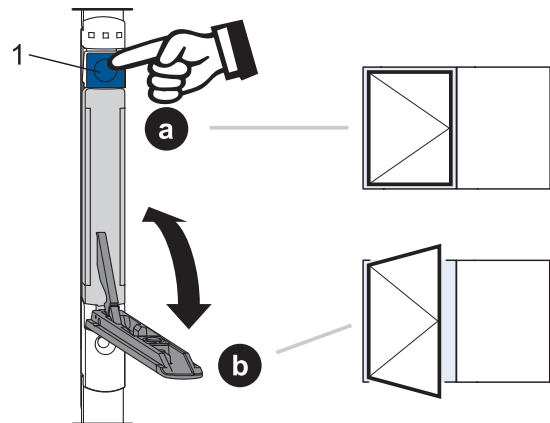

Function test turn double sash window

Adjustment options

Octagonal bolt

Regulate the contact pressure between the sash and the frame (± 0.8 mm) by turning the octagonal bolt. The adjustment can be carried out by means of the Winkhaus adjustment key (V.ST.SCH.HV-11).

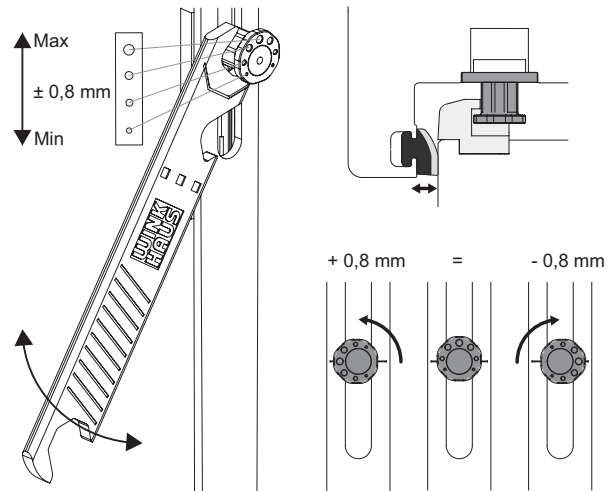

Octagonal bolt

Shears

The sash is raised and lowered by adjusting the shear slide-way.

The sash can be raised 2.5 mm and lowered 1.5 mm.

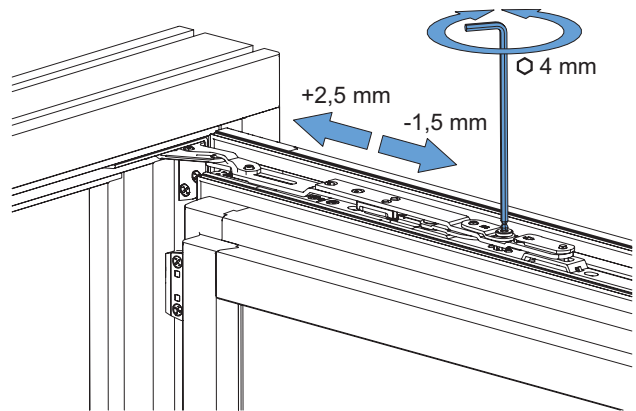

Shears

Adjustment options

Height and side adjustment

Corner and Sash Hinges

Adjustment tool: Allen key with ball head (size 4)

- Height adjustment +2 mm / -1.5 mm (1)
- Side adjustment +2.5 mm / -2.5 mm (2)

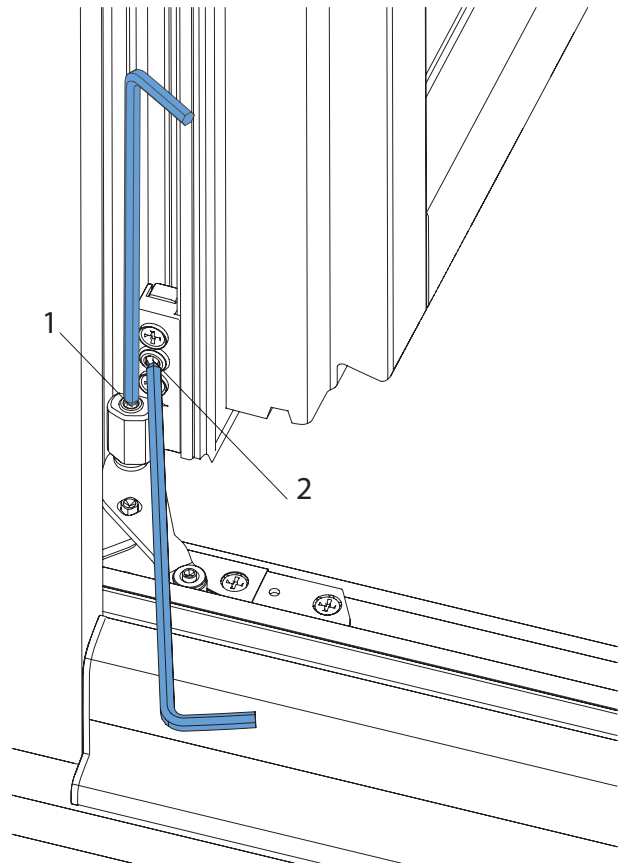

Height and side adjustment

Contact pressure adjustment

Sash hinges

Adjustment tool: Open-ended spanner (size 10)

- Pressure adjustment ± 0.8 mm

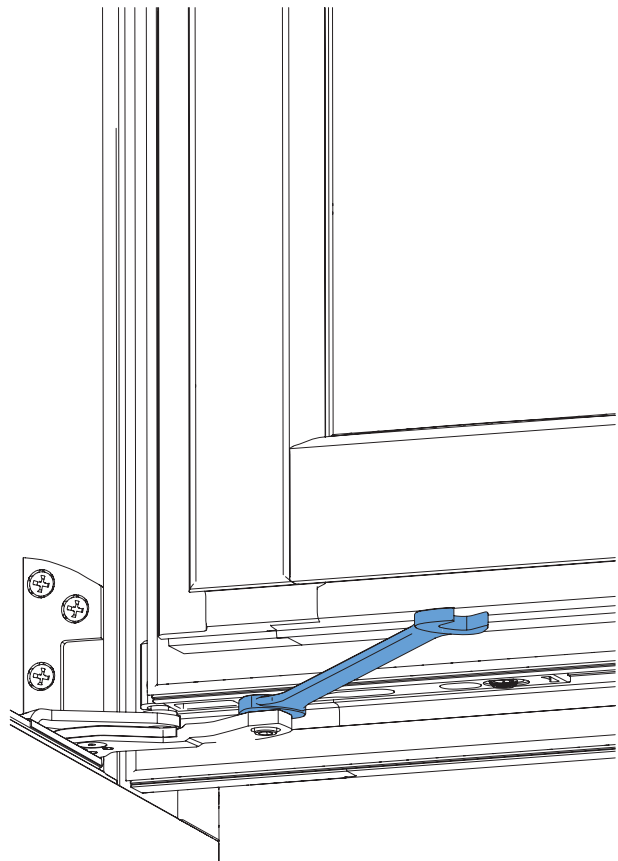

Contact pressure adjustment

Maintenance

Lubrication points

See figure: Overview of lubrication points

The figure shows the location of possible lubrication points which should be lubricated at least once a year (every six months for school and hotel buildings).

Positions A, C, D = lubrication points relevant to function.

Position B = safety-relevant lubrication point

i Note: The fitting schematic shown adjacent does not necessarily match the existing fitting. The number of locking positions will vary depending on size and type of the window sash.

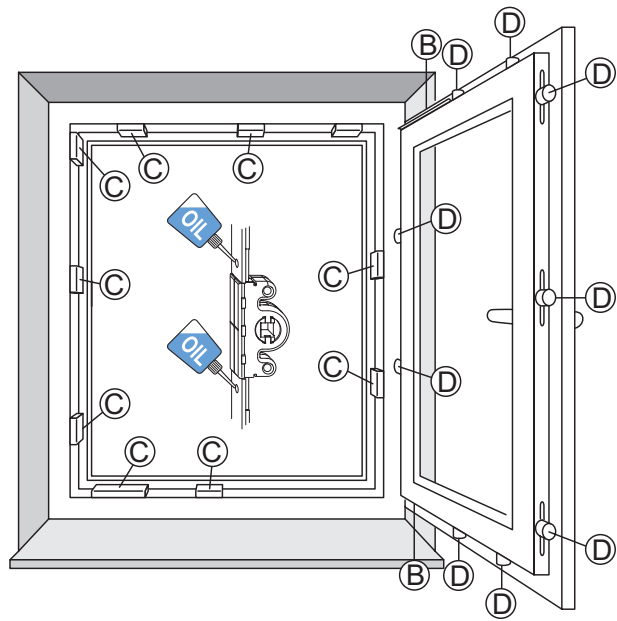

Overview of lubrication points

! Please note! Risk of injury. The window could fall on removal and thus injure persons. Do not remove the window for maintenance.

Locking keeps

See figure: Lubrication points

To keep fittings running smoothly, you must lubricate the keeps at least once a year.

- Lubricate the keeps (C) at the run-in side with technical Vaseline or any other suitable grease.
- Coat the running surfaces of the locking bolts (D) with an oil that is free of resins and acids.

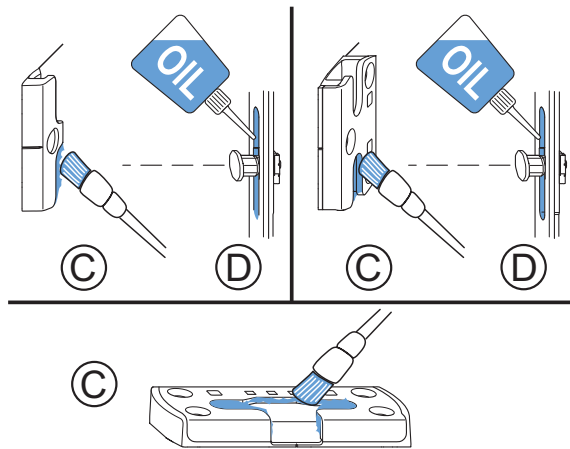

Lubrication points

Ascertaining the run-in sides

See figure: Run-in sides

- Left-handed window; handle right
- Right-handed window; handle left

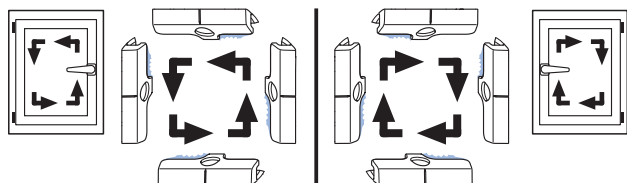

Run-in sides

Maintenance

Lubrication points

Shear and corner hinge

See figure: Shear and corner hinge

Fitting parts are to be tested regularly (at least once annually or semi-annually in schools and hotels) to ensure they are seated firmly and checked for wear. Fastening screws are to be retightened and parts replaced as necessary. Their functionality is to be retested afterwards.

All moving contact points on the shear and the corner hinge should be greased with a suitable lubricant at least once a year. Coat lubricating points with non-resinous, non-corroding grease.

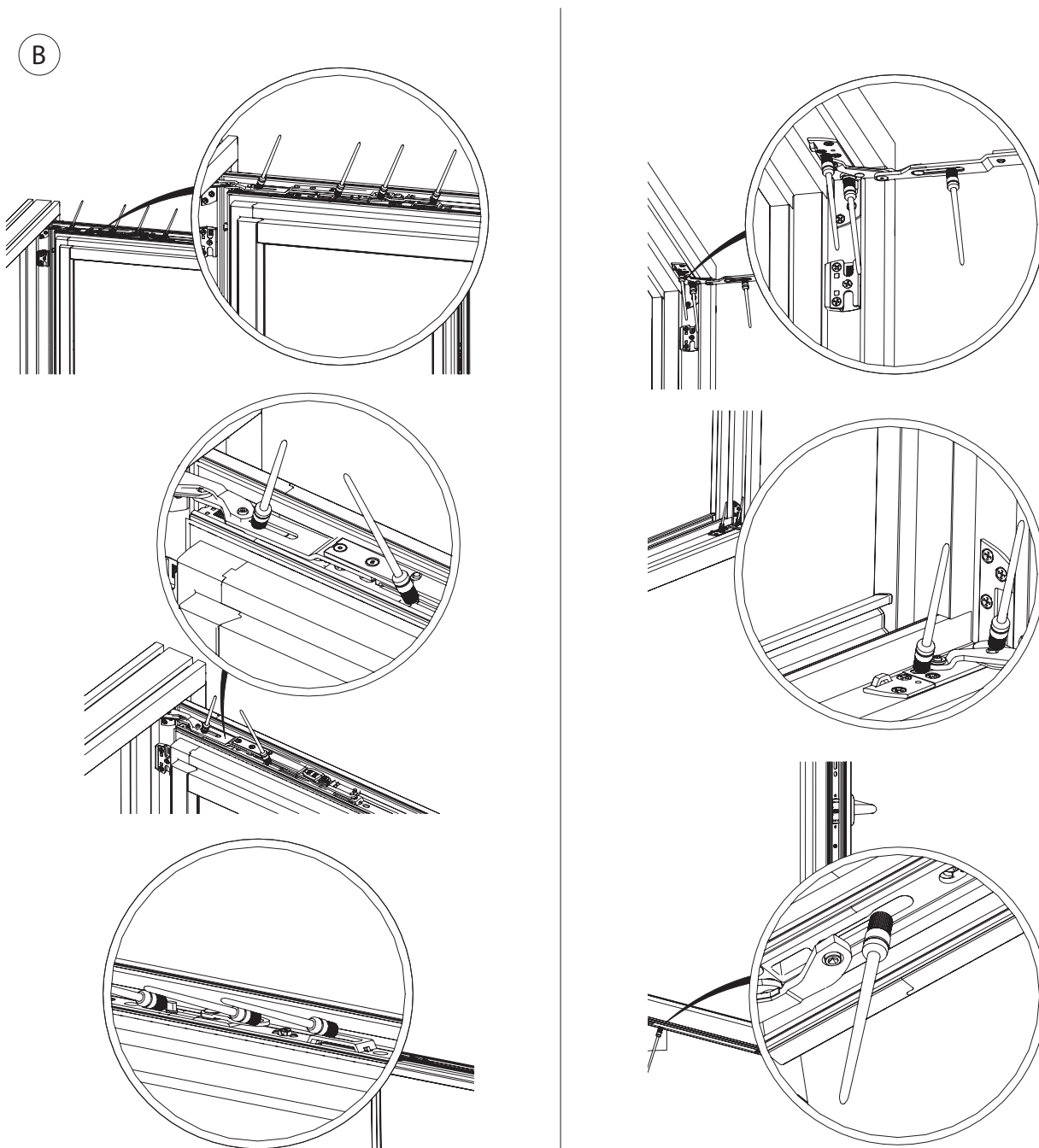

Please note! Risk of injury. The window could fall on removal and thus injure persons. Do not remove the window for maintenance.

Adjustment and maintenance

Dual/triple function element

DFE/TFE activation

The DFE/TFE element is supplied in the neutral position.

Please proceed as follows:

Drive in the protruding pin to fix in place (1).

Can be used left/right by swivelling out the lever once only.

Dribble a few drops of oil (free of resin and acid) onto lubrication points.

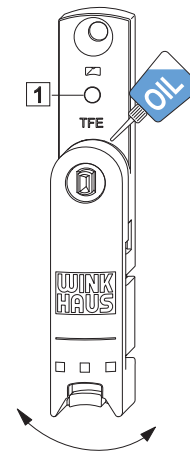

DFE/TFE activation

TFE – Retaining force of balcony door catch

Adjusting the holding force by re-setting the eccentric cam with a 4 mm Allen key.

Dribble a few drops of oil (free of resin and acid) onto lubrication points.

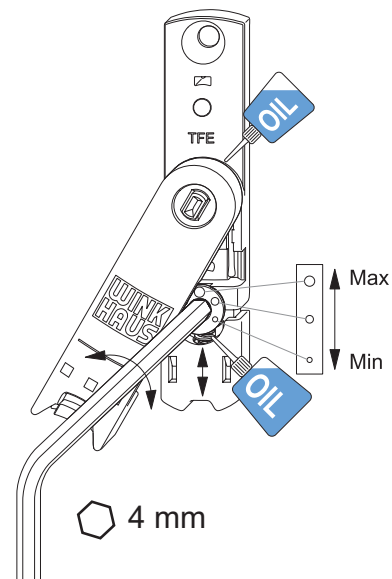

TFE – Retaining force of balcony door catch

Frame part DFE/TFE

Height adjustment (± 3 mm) for sash support plate.

Each time fittings are adjusted, the DFE/TFE height setting should also be checked using a 2.5 mm Allen key.

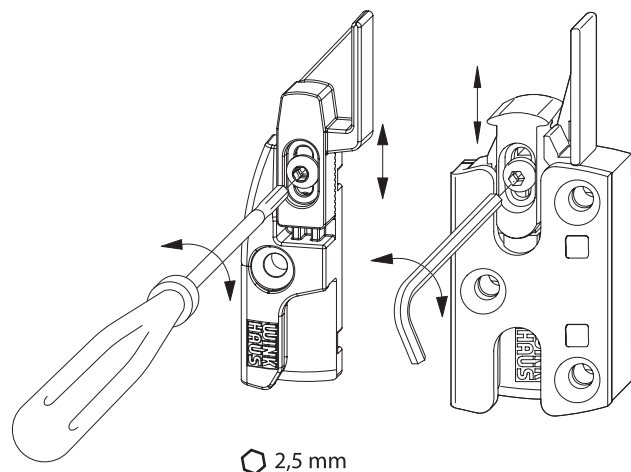

Frame part DFE/TFE

Installation drawings activPilot Topstar

Corner hinge, shear hinge, turn limiter

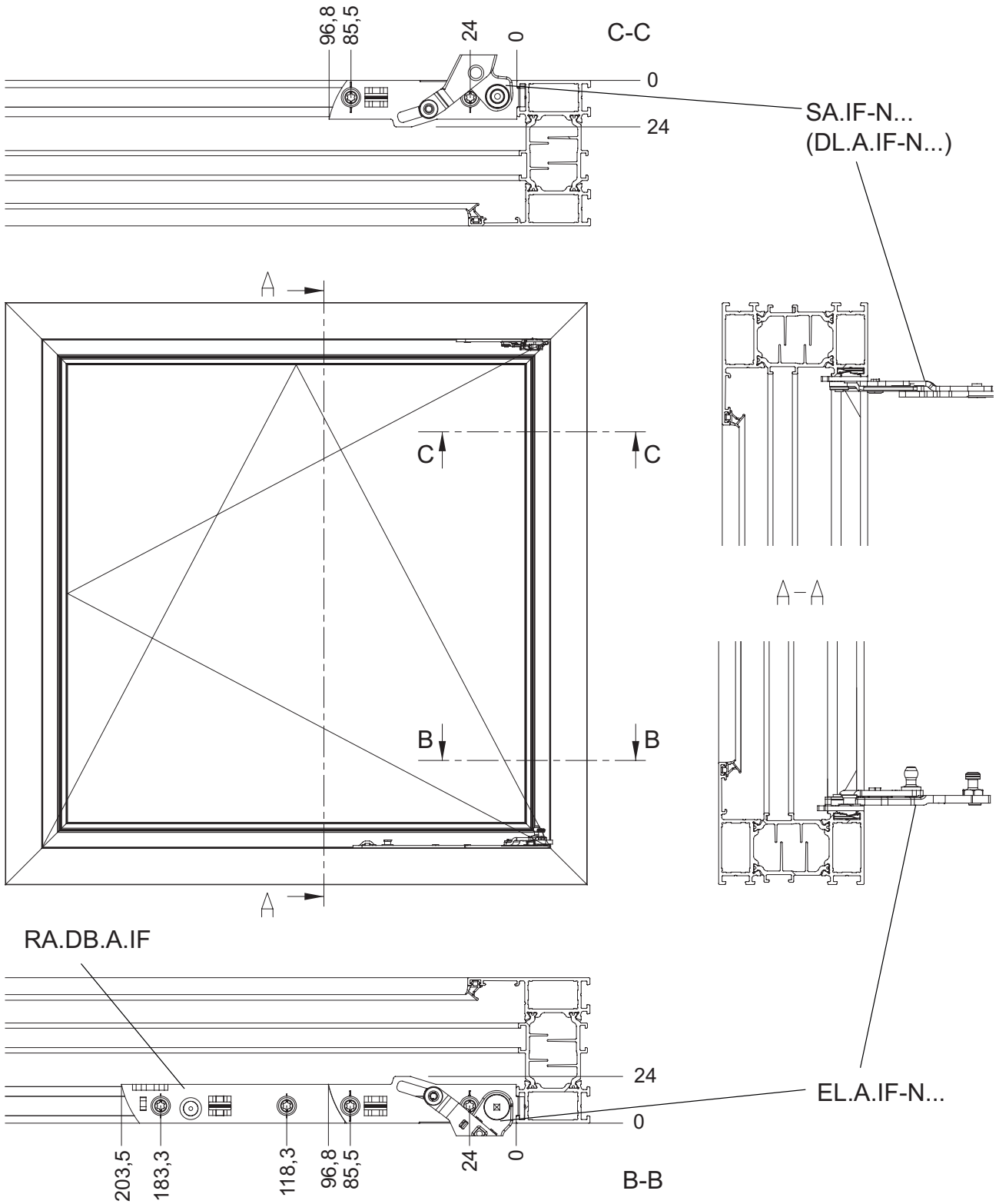

15

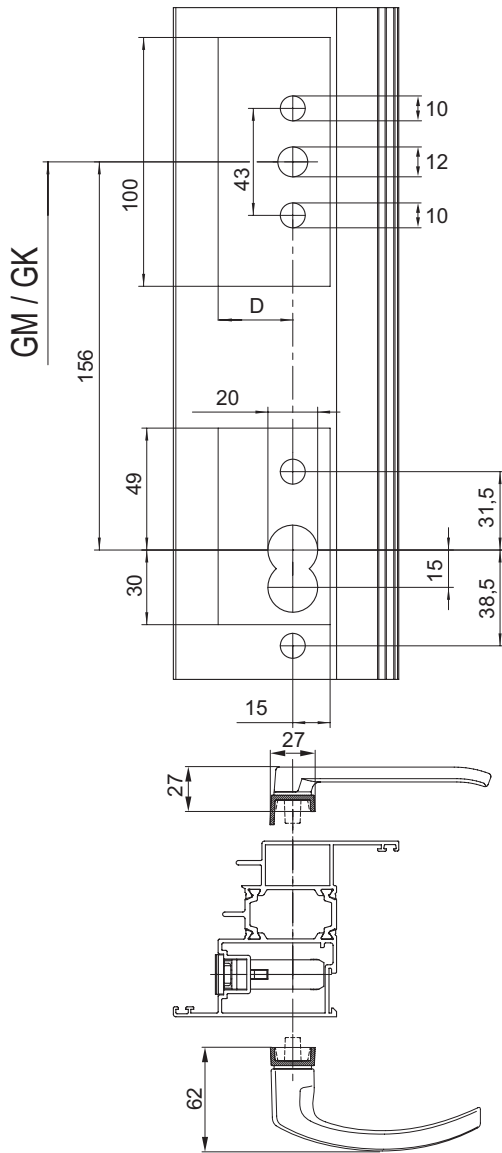

B-3-3: Drilling and milling instructions GAKA/GAMA D ...
D = Backset

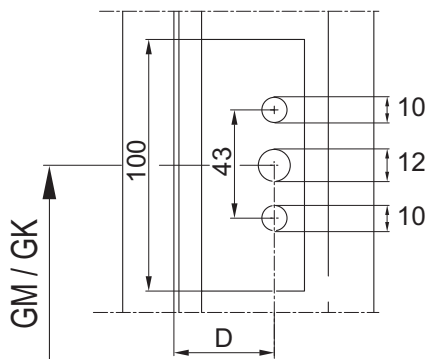

B-3-4: Drilling and milling template GAK/GAM ... D 25 ... 50
D = Backset

Additional shear

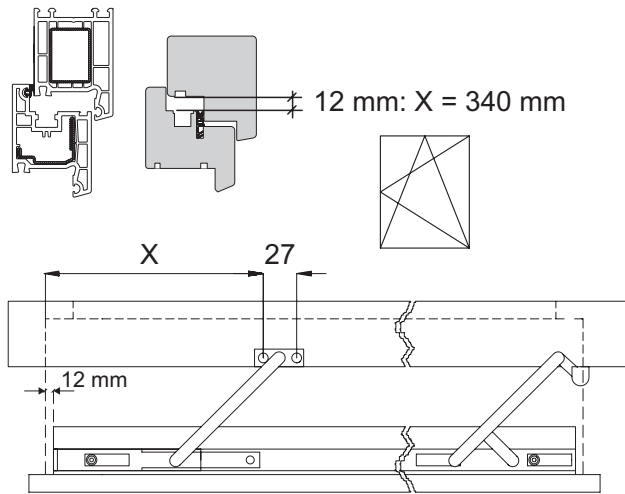

B-7-4: Installation drawing additional shear ZSR
(X with regard to frame rebate edge)

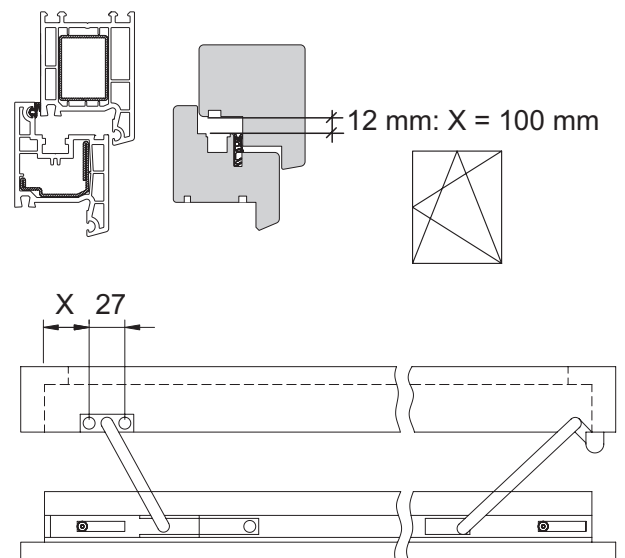

B-7-5: Installation drawing additional shear ZSRE (for fitting type "Tilt before turn")

Aug. Winkhaus GmbH & Co. KG

August-Winkhaus-Straße 31

D-48291 Telgte

T +49 2504 921-0

F +49 2504 921-340

fenstertechnik@winkhaus.de

winkhaus.com